

**ASME B16.20-2023**  
(Revision of ASME B16.20-2017)

# **Metallic Gaskets for Pipe Flanges**

---

ASMENORMDOC.COM : Click to view the full PDF of ASME B16.20-2023

**AN AMERICAN NATIONAL STANDARD**



**The American Society of  
Mechanical Engineers**

**ASME B16.20-2023**  
(Revision of ASME B16.20-2017)

# **Metallic Gaskets for Pipe Flanges**

---

ASMENORMDOC.COM : Click to view the full PDF of ASME B16.20 2023

**AN AMERICAN NATIONAL STANDARD**



**The American Society of  
Mechanical Engineers**

Two Park Avenue • New York, NY • 10016 USA

Date of Issuance: December 22, 2023

The next edition of this Standard is scheduled for publication in 2028.

This code or standard was developed under procedures accredited as meeting the criteria for American National Standards. The standards committee that approved the code or standard was balanced to ensure that individuals from competent and concerned interests had an opportunity to participate. The proposed code or standard was made available for public review and comment, which provided an opportunity for additional public input from industry, academia, regulatory agencies, and the public-at-large.

ASME does not “approve,” “certify,” “rate,” or “endorse” any item, construction, proprietary device, or activity. ASME does not take any position with respect to the validity of any patent rights asserted in connection with any items mentioned in this document, and does not undertake to insure anyone utilizing a standard against liability for infringement of any applicable letters patent, nor does ASME assume any such liability. Users of a code or standard are expressly advised that determination of the validity of any such patent rights, and the risk of infringement of such rights, is entirely their own responsibility.

Participation by federal agency representatives or persons affiliated with industry is not to be interpreted as government or industry endorsement of this code or standard.

ASME accepts responsibility for only those interpretations of this document issued in accordance with the established ASME procedures and policies, which precludes the issuance of interpretations by individuals.

The endnotes and preamble in this document (if any) are part of this American National Standard.



ASME Collective Membership Mark

“ASME” and the above ASME symbol are registered trademarks of The American Society of Mechanical Engineers.

No part of this document may be reproduced in any form,  
in an electronic retrieval system or otherwise,  
without the prior written permission of the publisher.

The American Society of Mechanical Engineers  
Two Park Avenue, New York, NY 10016-5990

Copyright © 2023 by  
THE AMERICAN SOCIETY OF MECHANICAL ENGINEERS  
All rights reserved  
Printed in U.S.A.

# CONTENTS

	Foreword .....	v
	Committee Roster .....	vi
	Correspondence With the B16 Committee .....	vii
	Important Information Concerning Use of Asbestos or Alternative Materials .....	ix
	Summary of Changes .....	x
	List of Changes in Record Number Order .....	xi
<b>Part GR</b>	<b>General Requirements</b> .....	1
GR-1	Scope .....	1
GR-2	Quality Systems .....	1
GR-3	References .....	1
GR-4	Relevant Units .....	1
<b>Part RJ</b>	<b>Ring-Joint Gaskets</b> .....	2
RJ-1	Types .....	2
RJ-2	Size .....	2
RJ-3	Materials .....	2
RJ-4	Marking .....	2
RJ-5	Dimensions and Tolerances .....	2
RJ-6	Surface Finish .....	2
RJ-7	Identification Number .....	2
<b>Part SW</b>	<b>Spiral-Wound Gaskets</b> .....	14
SW-1	Size and Class .....	14
SW-2	Dimensions and Tolerances .....	14
SW-3	Materials .....	15
SW-4	Marking .....	15
<b>Part GM</b>	<b>Grooved Metal Gaskets With Covering Layers</b> .....	34
GM-1	Size and Class .....	34
GM-2	Dimensions and Tolerances .....	34
GM-3	Materials .....	34
GM-4	Marking .....	34
<b>Mandatory Appendix</b>		
I	References .....	44
<b>Nonmandatory Appendix</b>		
A	Quality System Program .....	45
<b>Figures</b>		
SW-2.1-1	Spiral-Wound Gasket .....	16

GM-2.1-1	Grooved Metal Gasket With Covering Layers . . . . .	36
GM-4.1-1	Illustration of Example Markings for Grooved Metal Gaskets With Covering Layers . . . .	43
<b>Tables</b>		
RJ-3.2-1	Maximum Hardness for Ring Gaskets . . . . .	2
RJ-4-1	Ring Gasket Markings . . . . .	2
RJ-5-1	Type R Ring Gasket Dimensions and Tolerances . . . . .	3
RJ-5-2	Pipe Sizes for Type R Ring Gaskets Suitable for Referenced Standards . . . . .	6
RJ-5-3	Type RX Ring Gasket Dimensions and Tolerances . . . . .	9
RJ-5-4	Pipe Sizes for Type RX Ring Gaskets Suitable for Referenced Standards . . . . .	11
RJ-5-5	Type BX Ring Gasket Dimensions and Tolerances . . . . .	12
RJ-5-6	Pipe Sizes for Type BX Ring Gaskets Suitable for Referenced Standards . . . . .	13
SW-2.1-1	Dimensions for Spiral-Wound Gaskets Used With ASME B16.5 Flanges . . . . .	17
SW-2.1-2	Dimensions for Spiral-Wound Gaskets Used With ASME B16.47 Series A Flanges . . . . .	20
SW-2.1-3	Dimensions for Spiral-Wound Gaskets Used With ASME B16.47 Series B Flanges . . . . .	22
SW-2.1-4	Inside Diameters of Inner Rings for Spiral-Wound Gaskets for Use With ASME B16.5 Flanges	24
SW-2.1-5	Inside Diameters of Inner Rings for Spiral-Wound Gaskets Used Between ASME B16.47 Series A Flanges . . . . .	25
SW-2.1-6	Inside Diameters of Inner Rings for Spiral-Wound Gaskets Used Between ASME B16.47 Series B Flanges . . . . .	26
SW-2.5-1	Minimum Pipe Wall Thickness Suitable for Use of Spiral-Wound Gaskets With Inner Rings for ASME B16.5 Flanges . . . . .	27
SW-2.5-2	Maximum Bore of ASME B16.5 Flanges for Use With Spiral-Wound Gaskets . . . . .	28
SW-2.5-3	Maximum Bore of ASME B16.47 Series A Flanges for Use With Spiral-Wound Gaskets . .	29
SW-2.5-4	Maximum Bore of ASME B16.47 Series B Flanges for Use With Spiral-Wound Gaskets . .	30
SW-3-1	Color Coding and Abbreviations for Spiral-Wound Gasket Materials . . . . .	31
SW-4.1-1	Example Markings for Spiral-Wound Gaskets . . . . .	32
GM-2.1-1	Dimensions for Grooved Metal Gaskets With Covering Layers Used With ASME B16.5 Flanges	37
GM-2.1-2	Dimensions for Grooved Metal Gaskets With Covering Layers Used With ASME B16.47 Series A Flanges . . . . .	38
GM-2.1-3	Dimensions for Grooved Metal Gaskets With Covering Layers Used With ASME B16.47 Series B Flanges . . . . .	40
GM-3.1-1	Color Coding and Abbreviations for Grooved Metal Gaskets With Covering Layers Materials	42
GM-4.1-1	Example Markings for Grooved Metal Gaskets With Covering Layers . . . . .	43

# FOREWORD

Ring-joint gaskets and grooves probably originated in the boiler field, where they were used in various forms for manhole covers, autoclaves, and other closures; however, it was in the oil industry (both in the production and refining of oil) that they received the greatest recognition and were developed into their present form. Their use expanded steadily as temperatures and pressures were increased in steam plants. Tests examining their application in flanges and valves were conducted as early as 1928.

In June 1936, the American Petroleum Institute (API) issued Tentative Standard 5-G-3 on Ring-Joints for Steel Flanges and Flange Unions for use with API Tubular Goods. This standard was known as API Specification 6B, Ring-Joint Flanges. Following the acceptance of ring-joints for flanges and valves by API and the issuance of their standard, ASA B16e on Steel Pipe Flanges and Flanged Fittings was revised to include them, and the 1939 edition included standard dimensions for a full line of ring-joint flanges based on the API standard. Development work continued, and API formulated Standard 6E, Specification for Wellhead Equipment, which included ring-joints not covered in ASA B16e-1939.

In 1949, the American Standards Association (ASA), Sectional Committee B16, Subcommittee 3, Steel Flanges and Flanged Fittings, assembled the available information on ring-joint gaskets into a single standard. ASA approved the Standard, with the designation ASA B16.20-1952, on April 30, 1952.

On April 4, 1955, ASA approved an updated edition with the designation ASA B16.20-1955. Ring gaskets for Class 900 (900 lb at that time) in sizes NPS 26 through NPS 36 were added in the next edition, which ASA approved on April 2, 1956. The Standard was again reviewed in 1962, and ASA approved it on April 25, 1963. In 1973, the Standard was revised, and the American National Standards Institute (ANSI) approved it as an American National Standard.

Following publication of the 1973 edition, API requested that ASME convert their gasket standard, API 601, into an ASME American National Standard. As a result of that request, the Standard was expanded to include requirements for spiral-wound and jacketed gaskets that were formerly listed in API 601, 7th edition, 1988. Ring-joint groove dimensions were not included, because they were included in ASME/ANSI B16.5-1988, Pipe Flanges and Flanged Fittings, and ASME B16.47-1990, Large Diameter Steel Flanges. The revised Standard was approved by ANSI on January 22, 1993.

Subsequent editions further expanded the Standard. In the 1998 edition, a quality system program annex was added. In the 2007 edition, metric dimensions were adopted as an independent standard to the U.S. Customary units, and Mandatory Appendix I was added to cover dimensional tables in U.S. Customary units. In the 2012 edition, a new chapter for grooved metal gaskets with covering layers was added.

In the 2017 edition, the entire Standard was reorganized based on the different types of gaskets. In addition, the title of the Standard was revised, as were multiple paragraphs, tables, and figures. Following approval by the ASME B16 Standards Committee, ASME B16.20-2017 was approved by ANSI on October 11, 2017.

In ASME B16.20-2023, all references to double-jacketed gaskets have been removed, material abbreviations have been added as well as guidance for materials not listed in Table SW-3-1; other tables have been updated to align with ASME B16.5 and ASME B16.47. Following approval by the ASME B16 Standards Committee, ASME B16.20-2023 was approved by ANSI on October 9, 2023.

# ASME B16 COMMITTEE

## Standardization of Valves, Flanges, Fittings, and Gaskets

(The following is the roster of the committee at the time of approval of this Standard.)

### STANDARDS COMMITTEE OFFICERS

**C. E. Davila**, *Chair*  
**R. M. Bojarczuk**, *Vice Chair*  
**S. J. Rossi**, *Secretary*

### STANDARDS COMMITTEE PERSONNEL

<b>A. Appleton</b> , Appleton Quality Concepts, LLC	<b>D. Hunt, Jr.</b> , Fastenal
<b>J. E. Barker</b> , DeZURIK, Inc.	<b>G. A. Jolly</b> , Samshin, Ltd.
<b>R. W. Barnes</b> , ANRIC Enterprises, Inc.	<b>A. Kireta, Jr.</b> , Copper Development Association, Inc.
<b>D. C. Bayreuther</b> , Neles Corp.	<b>E. J. Lain</b> , Exelon Corp.
<b>W. B. Bedesem</b> , Consultant	<b>T. A. McMahon</b> , Emerson Automation Solutions
<b>R. M. Bojarczuk</b> , Retired	<b>R. C. Merrick</b> , Consultant
<b>A. M. Cheta</b> , Shell Global Solutions (U.S.)	<b>W. H. Patrick</b> , Dow Chemical Co.
<b>M. A. Clark</b> , Retired	<b>D. W. Raho</b> , CCM 2000
<b>G. A. Cuccio</b> , Capitol Manufacturing Co.	<b>D. F. Reid</b> , VSP Technologies
<b>C. E. Davila</b> , Crane Chempharma & Energy	<b>S. J. Rossi</b> , The American Society of Mechanical Engineers
<b>J. G. Dominguez</b> , Welding Outlets, Inc.	<b>R. A. Schmidt</b> , Canadoil
<b>B. G. Fabian</b> , Pennsylvania Machine Works	<b>J. Sekerak</b> , CSA Group
<b>K. S. Felder</b> , Valero Energy Corp.	<b>F. Feng</b> , <i>Delegate</i> , China Productivity Center for Machinery
<b>D. R. Frikken</b> , Becht Engineering Co., Inc.	<b>J. D. Grant</b> , <i>Alternate</i> , DeZURIK, Inc.
<b>J. Holstrom</b> , Val-Matic Valve & Manufacturing Corp.	<b>P. V. Craig</b> , <i>Contributing Member</i> , Jomar Group

### SUBCOMMITTEE G — GASKETS FOR FLANGED JOINTS

<b>E. J. Lain</b> , <i>Chair</i> , Exelon Corp.	<b>K. E. Guenther</b> , Shell
<b>A. Carrion</b> , <i>Secretary</i> , The American Society of Mechanical Engineers	<b>E. Jamalyaria</b> , Flexitallic Engineering
<b>R. M. Bojarczuk</b> , Retired	<b>Y. Li</b> , Flexitallic, L.P.
<b>G. Briggs</b> , James Walker Mooreflex, Ltd.	<b>L. Melvin</b> , Gasket Resources, Inc.
<b>M. Bush</b> , Marathon Petroleum Corp.	<b>B. Pourchot</b> , SGL Carbon
<b>D. Clover</b> , ERIKS North America	<b>D. F. Reid</b> , VSP Technologies
<b>K. S. Felder</b> , Valero Energy Corp.	<b>M. Ruffin</b> , Teadit North America, Inc.
<b>L. Fernandes</b> , Garlock Sealing Technologies	<b>S. Szemanek</b> , MIPC, LLC
<b>P. R. Francis</b> , Miami Valley Gasket Co., Inc.	<b>R. Taylor</b> , 3S — Superior Sealing Services, LLC
<b>D. R. Frikken</b> , Becht Engineering Co., Inc.	<b>D. Van Der Walt</b> , KLINGER GPI

# CORRESPONDENCE WITH THE B16 COMMITTEE

**General.** ASME codes and standards are developed and maintained by committees with the intent to represent the consensus of concerned interests. Users of ASME codes and standards may correspond with the committees to propose revisions or cases, report errata, or request interpretations. Correspondence for this Standard should be sent to the staff secretary noted on the committee's web page, accessible at <https://go.asme.org/B16committee>.

**Revisions and Errata.** The committee processes revisions to this Standard on a continuous basis to incorporate changes that appear necessary or desirable as demonstrated by the experience gained from the application of the Standard. Approved revisions will be published in the next edition of the Standard.

In addition, the committee may post errata on the committee web page. Errata become effective on the date posted. Users can register on the committee web page to receive e-mail notifications of posted errata.

This Standard is always open for comment, and the committee welcomes proposals for revisions. Such proposals should be as specific as possible, citing the paragraph number, the proposed wording, and a detailed description of the reasons for the proposal, including any pertinent background information and supporting documentation.

## Cases

(a) The most common applications for cases are

(1) to permit early implementation of a revision based on an urgent need

(2) to provide alternative requirements

(3) to allow users to gain experience with alternative or potential additional requirements prior to incorporation directly into the Standard

(4) to permit the use of a new material or process

(b) Users are cautioned that not all jurisdictions or owners automatically accept cases. Cases are not to be considered as approving, recommending, certifying, or endorsing any proprietary or specific design, or as limiting in any way the freedom of manufacturers, constructors, or owners to choose any method of design or any form of construction that conforms to the Standard.

(c) A proposed case shall be written as a question and reply in the same format as existing cases. The proposal shall also include the following information:

(1) a statement of need and background information

(2) the urgency of the case (e.g., the case concerns a project that is underway or imminent)

(3) the Standard and the paragraph, figure, or table number

(4) the editions of the Standard to which the proposed case applies

(d) A case is effective for use when the public review process has been completed and it is approved by the cognizant supervisory board. Approved cases are posted on the committee web page.

**Interpretations.** Upon request, the committee will issue an interpretation of any requirement of this Standard. An interpretation can be issued only in response to a request submitted through the online Interpretation Submittal Form at <https://go.asme.org/InterpretationRequest>. Upon submitting the form, the inquirer will receive an automatic e-mail confirming receipt.

ASME does not act as a consultant for specific engineering problems or for the general application or understanding of the Standard requirements. If, based on the information submitted, it is the opinion of the committee that the inquirer should seek assistance, the request will be returned with the recommendation that such assistance be obtained. Inquirers can track the status of their requests at <https://go.asme.org/Interpretations>.

ASME procedures provide for reconsideration of any interpretation when or if additional information that might affect an interpretation is available. Further, persons aggrieved by an interpretation may appeal to the cognizant ASME committee or subcommittee. ASME does not "approve," "certify," "rate," or "endorse" any item, construction, proprietary device, or activity.

Interpretations are published in the ASME Interpretations Database at <https://go.asme.org/Interpretations> as they are issued.



**Committee Meetings.** The B16 Standards Committee regularly holds meetings that are open to the public. Persons wishing to attend any meeting should contact the secretary of the committee. Information on future committee meetings can be found on the committee web page at <https://go.asme.org/B16committee>.

ASMENORMDOC.COM : Click to view the full PDF of ASME B16.20 2023

## IMPORTANT INFORMATION CONCERNING USE OF ASBESTOS OR ALTERNATIVE MATERIALS

Asbestos is referenced for use as a filler material in metallic gaskets. It has served as a universal sealing material, compatible with most fluid services. It has been of extreme usefulness in minimizing fire hazards.

Certain serious adverse health effects are associated with asbestos, among them the serious and often fatal diseases of lung cancer, asbestosis, and mesothelioma (a cancer of the chest and abdominal linings). The degree of exposure to asbestos varies with the product and the work practices involved.

Consult the most recent edition of the Occupational Safety and Health Administration, U.S. Department of Labor, Occupational Safety and Health Standard for Asbestos, Tremolite, Anthophyllite, and Actinolite, 29 Code of Federal Regulations Section 1910.1001; the U.S. Environmental Protection Agency National Emission Standard for Asbestos, 40 Code of Federal Regulations Sections 61.140 through 61.156; and the U.S. Environmental Protection Agency rule requiring the labeling and phased banning of asbestos products, published at 51 Federal Register 3738-3759 (January 29, 1986).

There are currently in use and under development a number of substitute materials to replace asbestos in certain applications. Manufacturers and users are encouraged to develop and use effective substitute materials that can meet the specifications for, and operating requirements of, the equipment to which they would apply.

Information concerning safety and health risks and proper precautions with respect to particular materials and conditions should be obtained from one's employer, the manufacturer or supplier of that material, or the Material Safety Data Sheet.

ASMENORMDOC.COM : Click to view the full PDF of ASME B16.20 2003

# ASME B16.20-2023

## SUMMARY OF CHANGES

Following approval by the ASME B16 Standards Committee and ASME, and after public review, ASME B16.20-2023 was approved by the American National Standards Institute on October 9, 2023.

ASME B16.20-2023 includes the following changes identified by a margin note, **(23)**. The Record Numbers listed below are explained in more detail in the “List of Changes in Record Number Order” following this Summary of Changes.

<i>Page</i>	<i>Location</i>	<i>Change (Record Number)</i>
1	GR-1	First sentence revised (12-517)
6	Table RJ-5-2	(1) For ASME B16.5, Class 900, entries for R-14, R-18, R-20, R-24, and R-27 revised (21-2166) (2) For ASME B16.5, Class 150 and Classes 300–600, entries for R-80 and R-81 revised (21-2144) (3) Note (3) added (21-2166)
14	SW-2.5	Sentence below subpara. (c) revised (21-2168)
15	SW-2.6	First paragraph and subpara. (b) revised (21-929)
15	SW-3	Revised (18-2515)
15	SW-4.1	Subparagraph (f) revised (21-2168)
17	Table SW-2.1-1	(1) NPS 22 added (19-856) (2) Note (5) revised and Note (6) added (19-856)
24	Table SW-2.1-4	(1) NPS 22 added (19-856) (2) Note (1) revised and Note (2) added (19-856)
27	Table SW-2.5-1	NPS 3½ and NPS 22 added (19-856)
28	Table SW-2.5-2	(1) NPS 3½ and NPS 22 added (19-856) (2) For NPS ½ through NPS 3½, Classes 400 and 900, entries revised (19-856)
31	Table SW-3-1	Revised in its entirety (18-2515)
33	Part JA	Deleted (12-517)
37	Table GM-2.1-1	(1) NPS 3½ and NPS 22 added (21-2145) (2) Note (4) revised (21-2145)
44	Mandatory Appendix I	Updated

## LIST OF CHANGES IN RECORD NUMBER ORDER

<u>Record Number</u>	<u>Change</u>
12-517	Removed all references to double-jacketed (DJ) gaskets from ASME B16.20.
18-2515	Revised Table SW-3-1 material abbreviations and para. SW-3. Included a larger range of materials used in construction. Added guidance for abbreviations for materials not listed in the table.
19-856	Added NPS 22 in Tables SW-2.1-1, SW-2.1-4, SW-2.5-1, and SW-2.5-2 to match what is currently in B16.5 and B16.47, and added new Notes.
21-929	Clarified spiral-wound gasket performance testing requirement.
21-2144	Added ring-joint gasket for 22 in. NPS ASME B16.5 flanges to ASME B16.20.
21-2145	Updated Table GM-2.1-1 to include 3½ in. NPS and 22 in. NPS ASME B16.5 flanges.
21-2166	Revised Table RJ-5-2 to add a Note to ½ in. to 2 in. for Class 900.
21-2168	Corrected "outer ring" to "centering ring." The term "outer ring" exists only within para. SW-2.6.

ASMENORMDOC.COM : Click to view the full PDF of ASME B16.20 2023

ASMENORMDOC.COM : Click to view the full PDF of ASME B16.20 2023

INTENTIONALLY LEFT BLANK

## PART GR GENERAL REQUIREMENTS

(23) **GR-1 SCOPE**

This Standard covers materials, dimensions, tolerances, and markings for metal ring-joint gaskets, spiral-wound metal gaskets, and grooved metal gaskets with covering layers. These gaskets are dimensionally suitable for use with flanges described in reference flange standards ASME B16.5, ASME B16.47, API Specification 6A, and ISO 10423.

**GR-2 QUALITY SYSTEMS**

Requirements relating to the product manufacturers' quality system programs are described in [Nonmandatory Appendix A](#).

**GR-3 REFERENCES**

Standards and specifications adopted by reference in this Standard are shown in [Mandatory Appendix I](#).

**GR-4 RELEVANT UNITS**

This Standard states values in both SI (Metric) and U.S. Customary units. These systems of units are to be regarded separately as standard. Within the text, the U.S. Customary units are shown in parentheses. The values stated in each system are not exact equivalents; therefore, it is required that each system of units be used independently of the other. Combining values from the two systems constitutes nonconformance with the Standard.

ASMENORMDOC.COM : Click to view the full PDF of ASME B16.20-2023

# PART RJ

## RING-JOINT GASKETS

### RJ-1 TYPES

Ring-joint gaskets shall be either octagonal or oval in cross section.

### RJ-2 SIZE

Ring-joint gaskets shall be identified by an R, RX, or BX number that relates to flange size (NPS), pressure class, and the appropriate flange standards (ASME B16.5, ASME B16.47, API Specification 6A, or ISO 10423).

### RJ-3 MATERIALS

#### RJ-3.1 General

Ring-joint gasket materials, some of which are listed in [Table RJ-3.2-1](#), shall be selected by the user based on suitability for the service conditions.

It is recommended that ring-joint gaskets be of a lesser hardness than that of the mating flanges.

#### RJ-3.2 Hardness

Ring-joint gaskets of materials listed in [Table RJ-3.2-1](#) shall have a hardness equal to or less than that shown in [Table RJ-3.2-1](#).

### RJ-4 MARKING

The outer surface of each gasket shall carry the manufacturer's name or identification trademark and gasket number prefixed by the letters R, RX, or BX, followed by the gasket material identification. Materials shall be identified as shown in [Table RJ-4-1](#). The gasket shall also be marked with an ASME B16.20 designation. The marking shall be applied so as not to harmfully distort the gasket or affect the integrity of the seal.

### RJ-5 DIMENSIONS AND TOLERANCES

Dimensions and tolerances for ring-joint gaskets shall be as shown in [Tables RJ-5-1](#) through [RJ-5-6](#).

### RJ-6 SURFACE FINISH

Types R and RX gaskets shall have a surface finish not rougher than 1.6  $\mu\text{m}$  (63  $\mu\text{in.}$ ) roughness. Type BX gaskets shall have a surface finish not rougher than 0.8  $\mu\text{m}$

(32  $\mu\text{in.}$ ) roughness. Surface finish shall pertain to the gasket-sealing surface.

### RJ-7 IDENTIFICATION NUMBER

Dimensional reference identification numbers are assigned to ring-joint gaskets and shown in [Tables RJ-5-1](#) through [RJ-5-6](#).

**Table RJ-3.2-1**  
**Maximum Hardness for Ring Gaskets**

Ring Gasket Material	Maximum Hardness	
	Brinell	Rockwell "B" Scale
Soft iron [Note (1)]	90	56
Low-carbon steel	120	68
4-6 chrome $\frac{1}{2}$ Mo	130	72
Type 410	170	86
Type 304	160	83
Type 316	160	83
Type 347	160	83

NOTE: (1) May be low-carbon steel, not to exceed maximum hardness of 90 Brinell — 56 Rockwell "B."

**Table RJ-4-1**  
**Ring Gasket Markings**

Ring Gasket Material	Identification	Marking Example [Note (1)]
Soft iron [Note (2)]	D	R51D
Low-carbon steel	S	R51S
4-6 chrome $\frac{1}{2}$ Mo	F5 [Note (3)]	R51F5
Type 410	S 410	R51S410
Type 304	S 304	R51S304
Type 316	S 316	R51S316
Type 347	S 347	R51S347

NOTES:

- (1) This number shall be preceded by the manufacturer's name or identification trademark.
- (2) May be low-carbon steel, not to exceed maximum hardness of 90 Brinell — 56 Rockwell "B."
- (3) F5 identification designates ASTM specification A182-72 chemical composition requirements only.

**Table RJ-5-1  
Type R Ring Gasket Dimensions and Tolerances**

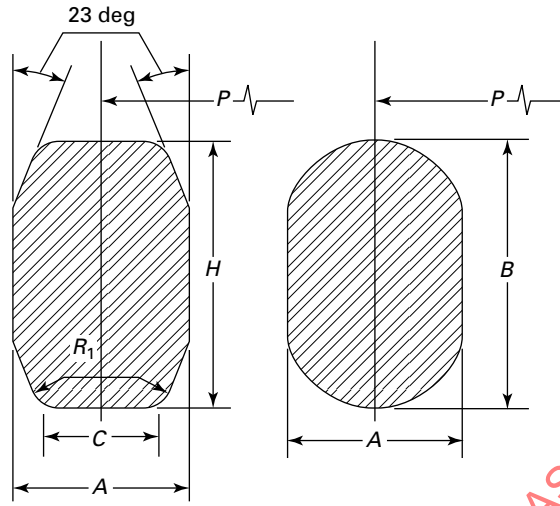

Ring Number	Average Pitch Diameter of Ring, P, mm (in.)	Width of Ring, A, mm (in.)	Height of Ring, mm (in.)		Width of Flat on Octagonal Ring, C, mm (in.)	Radius in Octagonal Ring, R <sub>1</sub> , mm (in.)
			Oval, B	Octagonal, H		
R-11	34.14 (1.344)	6.35 (0.250)	11.2 (0.44)	9.7 (0.38)	4.32 (0.170)	1.5 (0.06)
R-12	39.70 (1.563)	7.95 (0.313)	14.2 (0.56)	12.7 (0.50)	5.23 (0.206)	1.5 (0.06)
R-13	42.88 (1.688)	7.95 (0.313)	14.2 (0.56)	12.7 (0.50)	5.23 (0.206)	1.5 (0.06)
R-14	44.45 (1.750)	7.95 (0.313)	14.2 (0.56)	12.7 (0.50)	5.23 (0.206)	1.5 (0.06)
R-15	47.63 (1.875)	7.95 (0.313)	14.2 (0.56)	12.7 (0.50)	5.23 (0.206)	1.5 (0.06)
R-16	50.80 (2.000)	7.95 (0.313)	14.2 (0.56)	12.7 (0.50)	5.23 (0.206)	1.5 (0.06)
R-17	57.15 (2.250)	7.95 (0.313)	14.2 (0.56)	12.7 (0.50)	5.23 (0.206)	1.5 (0.06)
R-18	60.33 (2.375)	7.95 (0.313)	14.2 (0.56)	12.7 (0.50)	5.23 (0.206)	1.5 (0.06)
R-19	65.10 (2.563)	7.95 (0.313)	14.2 (0.56)	12.7 (0.50)	5.23 (0.206)	1.5 (0.06)
R-20	68.28 (2.688)	7.95 (0.313)	14.2 (0.56)	12.7 (0.50)	5.23 (0.206)	1.5 (0.06)
R-21	72.24 (2.844)	11.13 (0.438)	17.5 (0.69)	16.0 (0.63)	7.75 (0.305)	1.5 (0.06)
R-22	82.55 (3.250)	7.95 (0.313)	14.2 (0.56)	12.7 (0.50)	5.23 (0.206)	1.5 (0.06)
R-23	82.55 (3.250)	11.13 (0.438)	17.5 (0.69)	16.0 (0.63)	7.75 (0.305)	1.5 (0.06)
R-24	95.25 (3.750)	11.13 (0.438)	17.5 (0.69)	16.0 (0.63)	7.75 (0.305)	1.5 (0.06)
R-25	101.60 (4.000)	7.95 (0.313)	14.2 (0.56)	12.7 (0.50)	5.23 (0.206)	1.5 (0.06)
R-26	101.60 (4.000)	11.13 (0.438)	17.5 (0.69)	16.0 (0.63)	7.75 (0.305)	1.5 (0.06)
R-27	107.95 (4.250)	11.13 (0.438)	17.5 (0.69)	16.0 (0.63)	7.75 (0.305)	1.5 (0.06)
R-28	111.13 (4.375)	12.70 (0.500)	19.1 (0.75)	17.5 (0.69)	8.66 (0.341)	1.5 (0.06)
R-29	114.30 (4.500)	7.95 (0.313)	14.2 (0.56)	12.7 (0.50)	5.23 (0.206)	1.5 (0.06)
R-30	117.48 (4.625)	11.13 (0.438)	17.5 (0.69)	16.0 (0.63)	7.75 (0.305)	1.5 (0.06)
R-31	123.83 (4.875)	11.13 (0.438)	17.5 (0.69)	16.0 (0.63)	7.75 (0.305)	1.5 (0.06)
R-32	127.00 (5.000)	12.70 (0.500)	19.1 (0.75)	17.5 (0.69)	8.66 (0.341)	1.5 (0.06)
R-33	131.78 (5.188)	7.95 (0.313)	14.2 (0.56)	12.7 (0.50)	5.23 (0.206)	1.5 (0.06)
R-34	131.78 (5.188)	11.13 (0.438)	17.5 (0.69)	16.0 (0.63)	7.75 (0.305)	1.5 (0.06)
R-35	136.53 (5.375)	11.13 (0.438)	17.5 (0.69)	16.0 (0.63)	7.75 (0.305)	1.5 (0.06)
R-36	149.23 (5.875)	7.95 (0.313)	14.2 (0.56)	12.7 (0.50)	5.23 (0.206)	1.5 (0.06)
R-37	149.23 (5.875)	11.13 (0.438)	17.5 (0.69)	16.0 (0.63)	7.75 (0.305)	1.5 (0.06)
R-38	157.18 (6.188)	15.88 (0.625)	22.4 (0.88)	20.6 (0.81)	10.49 (0.413)	1.5 (0.06)



**Table RJ-5-1  
Type R Ring Gasket Dimensions and Tolerances (Cont'd)**

Ring Number	Average Pitch Diameter of Ring, <i>P</i> , mm (in.)	Width of Ring, <i>A</i> , mm (in.)	Height of Ring, mm (in.)		Width of Flat on Octagonal Ring, <i>C</i> , mm (in.)	Radius in Octagonal Ring, <i>R</i> <sub>1</sub> , mm (in.)
			Oval, <i>B</i>	Octagonal, <i>H</i>		
R-39	161.93 (6.375)	11.13 (0.438)	17.5 (0.69)	16.0 (0.63)	7.75 (0.305)	1.5 (0.06)
R-40	171.45 (6.750)	7.95 (0.313)	14.2 (0.56)	12.7 (0.50)	5.23 (0.206)	1.5 (0.06)
R-41	180.98 (7.125)	11.13 (0.438)	17.5 (0.69)	16.0 (0.63)	7.75 (0.305)	1.5 (0.06)
R-42	190.50 (7.500)	19.05 (0.750)	25.4 (1.00)	23.9 (0.94)	12.32 (0.485)	1.5 (0.06)
R-43	193.68 (7.625)	7.95 (0.313)	14.2 (0.56)	12.7 (0.50)	5.23 (0.206)	1.5 (0.06)
R-44	193.68 (7.625)	11.13 (0.438)	17.5 (0.69)	16.0 (0.63)	7.75 (0.305)	1.5 (0.06)
R-45	211.15 (8.313)	11.13 (0.438)	17.5 (0.69)	16.0 (0.63)	7.75 (0.305)	1.5 (0.06)
R-46	211.15 (8.313)	12.70 (0.500)	19.1 (0.75)	17.5 (0.69)	8.66 (0.341)	1.5 (0.06)
R-47	228.60 (9.000)	19.05 (0.750)	25.4 (1.00)	23.9 (0.94)	12.32 (0.485)	1.5 (0.06)
R-48	247.65 (9.750)	7.95 (0.313)	14.2 (0.56)	12.7 (0.50)	5.23 (0.206)	1.5 (0.06)
R-49	269.88 (10.625)	11.13 (0.438)	17.5 (0.69)	16.0 (0.63)	7.75 (0.305)	1.5 (0.06)
R-50	269.88 (10.625)	15.88 (0.625)	22.4 (0.88)	20.6 (0.81)	10.49 (0.413)	1.5 (0.06)
R-51	279.40 (11.000)	22.23 (0.875)	28.7 (1.13)	26.9 (1.06)	14.81 (0.583)	1.5 (0.06)
R-52	304.80 (12.000)	7.95 (0.313)	14.2 (0.56)	12.7 (0.50)	5.23 (0.206)	1.5 (0.06)
R-53	323.85 (12.750)	11.13 (0.438)	17.5 (0.69)	16.0 (0.63)	7.75 (0.305)	1.5 (0.06)
R-54	323.85 (12.750)	15.88 (0.625)	22.4 (0.88)	20.6 (0.81)	10.49 (0.413)	1.5 (0.06)
R-55	342.90 (13.500)	28.58 (1.125)	36.6 (1.44)	35.1 (1.38)	19.81 (0.780)	2.3 (0.09)
R-56	381.00 (15.000)	7.95 (0.313)	14.2 (0.56)	12.7 (0.50)	5.23 (0.206)	1.5 (0.06)
R-57	381.00 (15.000)	11.13 (0.438)	17.5 (0.69)	16.0 (0.63)	7.75 (0.305)	1.5 (0.06)
R-58	381.00 (15.000)	22.23 (0.875)	28.7 (1.13)	26.9 (1.06)	14.81 (0.583)	1.5 (0.06)
R-59	396.88 (15.625)	7.95 (0.313)	14.2 (0.56)	12.7 (0.50)	5.23 (0.206)	1.5 (0.06)
R-60	406.40 (16.000)	31.75 (1.250)	39.6 (1.56)	38.1 (1.50)	22.33 (0.879)	2.3 (0.09)
R-61	419.10 (16.500)	11.13 (0.438)	17.5 (0.69)	16.0 (0.63)	7.75 (0.305)	1.5 (0.06)
R-62	419.10 (16.500)	15.88 (0.625)	22.4 (0.88)	20.6 (0.81)	10.49 (0.413)	1.5 (0.06)
R-63	419.10 (16.500)	25.40 (1.000)	33.3 (1.31)	31.8 (1.25)	17.30 (0.681)	2.3 (0.09)
R-64	454.03 (17.875)	7.95 (0.313)	14.2 (0.56)	12.7 (0.50)	5.23 (0.206)	1.5 (0.06)
R-65	469.90 (18.500)	11.13 (0.438)	17.5 (0.69)	16.0 (0.63)	7.75 (0.305)	1.5 (0.06)
R-66	469.90 (18.500)	15.88 (0.625)	22.4 (0.88)	20.6 (0.81)	10.49 (0.413)	1.5 (0.06)
R-67	469.90 (18.500)	28.58 (1.125)	36.6 (1.44)	35.1 (1.38)	19.81 (0.780)	2.3 (0.09)
R-68	517.53 (20.375)	7.95 (0.313)	14.2 (0.56)	12.7 (0.50)	5.23 (0.206)	1.5 (0.06)
R-69	533.40 (21.000)	11.13 (0.438)	17.5 (0.69)	16.0 (0.63)	7.75 (0.305)	1.5 (0.06)
R-70	533.40 (21.000)	19.05 (0.750)	25.4 (1.00)	23.9 (0.94)	12.32 (0.485)	1.5 (0.06)
R-71	533.40 (21.000)	28.58 (1.125)	36.6 (1.44)	35.1 (1.38)	19.81 (0.780)	2.3 (0.09)
R-72	558.80 (22.000)	7.95 (0.313)	14.2 (0.56)	12.7 (0.50)	5.23 (0.206)	1.5 (0.06)
R-73	584.20 (23.000)	12.70 (0.500)	19.1 (0.75)	17.5 (0.69)	8.66 (0.341)	1.5 (0.06)
R-74	584.20 (23.000)	19.05 (0.750)	25.4 (1.00)	23.9 (0.94)	12.32 (0.485)	1.5 (0.06)
R-75	584.20 (23.000)	31.75 (1.250)	39.6 (1.56)	38.1 (1.50)	22.33 (0.879)	2.3 (0.09)
R-76	673.10 (26.500)	7.95 (0.313)	14.2 (0.56)	12.7 (0.50)	5.23 (0.206)	1.5 (0.06)
R-77	692.15 (27.250)	15.88 (0.625)	22.4 (0.88)	20.6 (0.81)	10.49 (0.413)	1.5 (0.06)
R-78	692.15 (27.250)	25.40 (1.000)	33.3 (1.31)	31.8 (1.25)	17.30 (0.681)	2.3 (0.09)
R-79	692.15 (27.250)	34.93 (1.375)	44.5 (1.75)	41.4 (1.63)	24.82 (0.977)	2.3 (0.09)
R-80	615.95 (24.250)	7.95 (0.313)	...	12.7 (0.50)	5.23 (0.206)	1.5 (0.06)

**Table RJ-5-1  
Type R Ring Gasket Dimensions and Tolerances (Cont'd)**

Ring Number	Average Pitch Diameter of Ring, <i>P</i> , mm (in.)	Width of Ring, <i>A</i> , mm (in.)	Height of Ring, mm (in.)		Width of Flat on Octagonal Ring, <i>C</i> , mm (in.)	Radius in Octagonal Ring, <i>R</i> <sub>1</sub> , mm (in.)
			Oval, <i>B</i>	Octagonal, <i>H</i>		
R-81	635.00 (25.000)	14.30 (0.563)	...	19.1 (0.75)	9.58 (0.377)	1.5 (0.06)
R-82	57.15 (2.250)	11.13 (0.438)	...	16.0 (0.63)	7.75 (0.305)	1.5 (0.06)
R-84	63.50 (2.500)	11.13 (0.438)	...	16.0 (0.63)	7.75 (0.305)	1.5 (0.06)
R-85	79.38 (3.125)	12.70 (0.500)	...	17.5 (0.69)	8.66 (0.341)	1.5 (0.06)
R-86	90.50 (3.563)	15.88 (0.625)	...	20.6 (0.81)	10.49 (0.413)	1.5 (0.06)
R-87	100.03 (3.938)	15.88 (0.625)	...	20.6 (0.81)	10.49 (0.413)	1.5 (0.06)
R-88	123.83 (4.875)	19.05 (0.750)	...	23.9 (0.94)	12.32 (0.485)	1.5 (0.06)
R-89	114.30 (4.500)	19.05 (0.750)	...	23.9 (0.94)	12.32 (0.485)	1.5 (0.06)
R-90	155.58 (6.125)	22.23 (0.875)	...	26.9 (1.06)	14.81 (0.583)	1.5 (0.06)
R-91	260.35 (10.250)	31.75 (1.250)	...	38.1 (1.50)	22.33 (0.879)	2.3 (0.09)
R-92	228.60 (9.000)	11.13 (0.438)	17.5 (0.69)	16.0 (0.63)	7.75 (0.305)	1.5 (0.06)
R-93	749.30 (29.500)	19.05 (0.750)	...	23.9 (0.94)	12.32 (0.485)	1.5 (0.06)
R-94	800.10 (31.500)	19.05 (0.750)	...	23.9 (0.94)	12.32 (0.485)	1.5 (0.06)
R-95	857.25 (33.750)	19.05 (0.750)	...	23.9 (0.94)	12.32 (0.485)	1.5 (0.06)
R-96	914.40 (36.000)	22.23 (0.875)	...	26.9 (1.06)	14.81 (0.583)	1.5 (0.06)
R-97	965.20 (38.000)	22.23 (0.875)	...	26.9 (1.06)	14.81 (0.583)	1.5 (0.06)
R-98	1 022.35 (40.250)	22.23 (0.875)	...	26.9 (1.06)	14.81 (0.583)	1.5 (0.06)
R-99	234.95 (9.250)	11.13 (0.438)	...	16.0 (0.63)	7.75 (0.305)	1.5 (0.06)
R-100	749.30 (29.500)	28.58 (1.125)	...	35.1 (1.38)	19.81 (0.780)	2.3 (0.09)
R-101	800.10 (31.500)	31.75 (1.250)	...	38.1 (1.50)	22.33 (0.879)	2.3 (0.09)
R-102	857.25 (33.750)	31.75 (1.250)	...	38.1 (1.50)	22.33 (0.879)	2.3 (0.09)
R-103	914.40 (36.000)	31.75 (1.250)	...	38.1 (1.50)	22.33 (0.879)	2.3 (0.09)
R-104	965.20 (38.000)	34.93 (1.375)	...	41.4 (1.63)	24.82 (0.977)	2.3 (0.09)
R-105	1 022.35 (40.250)	34.93 (1.375)	...	41.4 (1.63)	24.82 (0.977)	2.3 (0.09)

## GENERAL NOTE: Tolerances:

23 deg = angle,  $\pm 0$  deg 30 min ( $\pm 1/2$  deg)*A* = width of ring,  $\pm 0.20$  mm ( $\pm 0.008$  in.)*B*, *H* = height of ring, +1.3 mm, -0.5 mm (+0.05 in., -0.02 in.)

Variation in height throughout the entire circumference of any given ring shall not exceed 0.5 mm (0.02 in.) within these tolerances.

*C* = width of flat on octagonal ring,  $\pm 0.20$  mm ( $\pm 0.008$  in.)*P* = average pitch diameter of ring,  $\pm 0.18$  mm ( $\pm 0.007$  in.)*R*<sub>1</sub> = radius in ring,  $\pm 0.5$  mm ( $\pm 0.02$  in.)

(23)

**Table RJ-5-2  
Pipe Sizes for Type R Ring Gaskets Suitable for Referenced Standards**

Ring Number	Pipe Size, NPS, by Pressure Class											
	ASME B16.5					API 6B				ASME B16.47 Series A		
	150	300-600	900	1500	2500	720-960 [Note (1)]	2000	3000	5000	150	300-600	900
R-11	...	1/2	...	...	...	...	...	...	...	...	...	...
R-12	...	...	[Note (2)]	1/2	...	...	...	...	...	...	...	...
R-13	...	3/4	...	...	1/2	...	...	...	...	...	...	...
R-14	...	...	[Note (2)]	3/4	...	...	...	...	...	...	...	...
R-15	1	...	...	...	...	...	...	...	...	...	...	...
R-16	...	1	1	1	3/4	1	1	1	1	...	...	...
R-17	1 1/4	...	...	...	...	...	...	...	...	...	...	...
R-18	...	1 1/4	[Note (2)]	1 1/4	1	1 1/4	1 1/4	1 1/4	1 1/4	...	...	...
R-19	1 1/2	...	...	...	...	...	...	...	...	...	...	...
R-20	...	1 1/2	[Note (2)]	1 1/2	...	1 1/2	1 1/2	1 1/2	1 1/2	...	...	...
R-21	...	...	...	...	1 1/4	...	...	...	...	...	...	...
R-22	2	...	...	...	...	...	...	...	...	...	...	...
R-23	...	2	...	...	1 1/2	2	2	...	...	...	...	...
R-24	...	...	[Note (2)]	2	...	...	...	2	2	...	...	...
R-25	2 1/2	...	...	...	...	...	...	...	...	...	...	...
R-26	...	2 1/2	...	...	2	2 1/2	2 1/2	...	...	...	...	...
R-27	...	...	[Note (2)]	2 1/2	...	...	...	2 1/2	2 1/2	...	...	...
R-28	...	...	...	...	2 1/2	...	...	...	...	...	...	...
R-29	3	...	...	...	...	...	...	...	...	...	...	...
R-30 [Note (3)]	...	3	...	...	...	...	...	...	...	...	...	...
R-31	...	3	3	...	...	3	3	3	...	...	...	...
R-32	...	...	...	...	3	...	...	...	...	...	...	...
R-33	3 1/2	...	...	...	...	...	...	...	...	...	...	...
R-34	...	3 1/2	...	...	...	...	...	...	...	...	...	...
R-35	...	...	...	3	...	...	...	...	3	...	...	...
R-36	4	...	...	...	...	...	...	...	...	...	...	...
R-37	...	4	4	...	...	4	4	4	3 1/2	...	...	...
R-38	...	...	...	...	4	...	...	...	...	...	...	...
R-39	...	...	...	4	...	...	...	...	4	...	...	...
R-40	5	...	...	...	...	...	...	...	...	...	...	...
R-41	...	5	5	...	...	5	5	5	...	...	...	...
R-42	...	...	...	...	5	...	...	...	...	...	...	...
R-43	6	...	...	...	...	...	...	...	...	...	...	...
R-44	...	...	...	5	...	...	...	...	5	...	...	...
R-45	...	6	6	...	...	6	6	6	...	...	...	...
R-46	...	...	...	6	...	...	...	...	6	...	...	...
R-47	...	...	...	...	6	...	...	...	...	...	...	...
R-48	8	...	...	...	...	...	...	...	...	...	...	...
R-49	...	8	8	...	...	8	8	8	...	...	...	...

ASMEB16.20-2023.COM : Click to view the full PDF of ASME B16.20 2023

**Table RJ-5-2  
Pipe Sizes for Type R Ring Gaskets Suitable for Referenced Standards (Cont'd)**

Ring Number	Pipe Size, NPS, by Pressure Class											
	ASME B16.5					API 6B				ASME B16.47 Series A		
	150	300-600	900	1500	2500	720-960 [Note (1)]	2000	3000	5000	150	300-600	900
R-50	...	...	...	8	...	...	...	...	8	...	...	...
R-51	...	...	...	...	8	...	...	...	...	...	...	...
R-52	10	...	...	...	...	...	...	...	...	...	...	...
R-53	...	10	10	...	...	10	10	10	...	...	...	...
R-54	...	...	...	10	...	...	...	...	10	...	...	...
R-55	...	...	...	...	10	...	...	...	...	...	...	...
R-56	12	...	...	...	...	...	...	...	...	...	...	...
R-57	...	12	12	...	...	12	12	12	...	...	...	...
R-58	...	...	...	12	...	...	...	...	...	...	...	...
R-59	14	...	...	...	...	...	...	...	...	...	...	...
R-60	...	...	...	...	12	...	...	...	...	...	...	...
R-61	...	14	...	...	...	14	14	14	...	...	...	...
R-62	...	...	14	...	...	...	...	...	...	...	...	...
R-63	...	...	...	14	...	...	...	...	...	...	...	...
R-64	16	...	...	...	...	...	...	...	...	...	...	...
R-65	...	16	...	...	...	16	16	...	...	...	...	...
R-66	...	...	16	...	...	...	...	16	...	...	...	...
R-67	...	...	...	16	...	...	...	...	...	...	...	...
R-68	18	...	...	...	...	...	...	...	...	...	...	...
R-69	...	18	...	...	...	18	18	...	...	...	...	...
R-70	...	...	18	...	...	...	...	18	...	...	...	...
R-71	...	...	...	18	...	...	...	...	...	...	...	...
R-72	20	...	...	...	...	...	...	...	...	...	...	...
R-73	...	20	...	...	...	20	20	...	...	...	...	...
R-74	...	...	20	...	...	...	...	20	...	...	...	...
R-75	...	...	...	20	...	...	...	...	...	...	...	...
R-76	24	...	...	...	...	...	...	...	...	...	...	...
R-77	...	24	...	...	...	...	...	...	...	...	...	...
R-78	...	...	24	...	...	...	...	...	...	...	...	...
R-79	...	...	...	24	...	...	...	...	...	...	...	...
R-80	22	...	...	...	...	...	...	...	...	...	...	...
R-81	...	22	...	...	...	...	...	...	...	...	...	...
R-82	...	...	...	...	...	...	...	...	1	...	...	...
R-84	...	...	...	...	...	...	...	...	1½	...	...	...
R-85	...	...	...	...	...	...	...	...	2	...	...	...
R-86	...	...	...	...	...	...	...	...	2½	...	...	...
R-87	...	...	...	...	...	...	...	...	3	...	...	...
R-88	...	...	...	...	...	...	...	...	4	...	...	...

**Table RJ-5-2  
Pipe Sizes for Type R Ring Gaskets Suitable for Referenced Standards (Cont'd)**

Ring Number	Pipe Size, NPS, by Pressure Class											
	ASME B16.5					API 6B				ASME B16.47 Series A		
	150	300-600	900	1500	2500	720-960 [Note (1)]	2000	3000	5000	150	300-600	900
R-89	...	...	...	...	...	...	...	...	3½	...	...	...
R-90	...	...	...	...	...	...	...	...	5	...	...	...
R-91	...	...	...	...	...	...	...	...	10	...	...	...
R-92	...	...	...	...	...	...	...	...	...	...	...	...
R-93	...	...	...	...	...	...	...	...	...	...	26	...
R-94	...	...	...	...	...	...	...	...	...	...	28	...
R-95	...	...	...	...	...	...	...	...	...	...	30	...
R-96	...	...	...	...	...	...	...	...	...	...	32	...
R-97	...	...	...	...	...	...	...	...	...	...	34	...
R-98	...	...	...	...	...	...	...	...	...	...	36	...
R-99	...	...	...	...	...	...	8	8	...	...	...	...
R-100	...	...	...	...	...	...	...	...	...	...	...	26
R-101	...	...	...	...	...	...	...	...	...	...	...	28
R-102	...	...	...	...	...	...	...	...	...	...	...	30
R-103	...	...	...	...	...	...	...	...	...	...	...	32
R-104	...	...	...	...	...	...	...	...	...	...	...	34
R-105	...	...	...	...	...	...	...	...	...	...	...	36

GENERAL NOTE: End flanges to API 6D and API 600 use gaskets for equivalent pipe size under ASME B16.5 or ASME B16.47 Series A.

NOTES:

(1) Class 720, 960, and 10000 flanges to API 6B are obsolete. Data are for information only.

(2) There are no Class 900 flanges in NPS ½ through NPS 2½ (use Class 1500).

(3) R-30 is for lapped joint only.

**Table RJ-5-3  
Type RX Ring Gasket Dimensions and Tolerances**

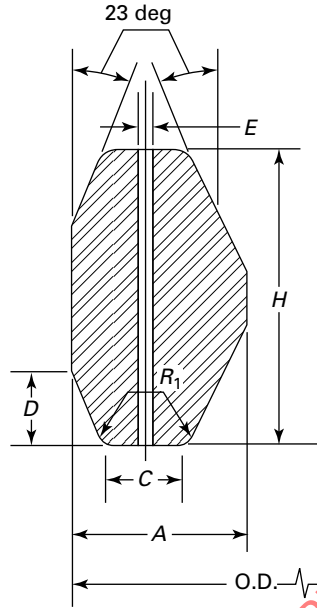

Ring Number	Outside Diameter of Ring, O.D., mm (in.)	Width of Ring, A, mm (in.)	Width of Flat, C, mm (in.)	Height of Outside Bevel, D, mm (in.)	Height of Ring, H, mm (in.)	Radius in Octagonal Ring, R <sub>1</sub> , mm (in.)	Hole Size, E, mm (in.) [Note (1)]
RX-20	76.20 (3.000)	8.74 (0.344)	4.62 (0.182)	3.18 (0.125)	19.05 (0.750)	1.5 (0.06)	...
RX-23	93.27 (3.672)	11.91 (0.469)	6.45 (0.254)	4.24 (0.167)	25.40 (1.000)	1.5 (0.06)	...
RX-24	105.97 (4.172)	11.91 (0.469)	6.45 (0.254)	4.24 (0.167)	25.40 (1.000)	1.5 (0.06)	...
RX-25	109.55 (4.313)	8.74 (0.344)	4.62 (0.182)	3.18 (0.125)	19.05 (0.750)	1.5 (0.06)	...
RX-26	111.91 (4.406)	11.91 (0.469)	6.45 (0.254)	4.24 (0.167)	25.40 (1.000)	1.5 (0.06)	...
RX-27	118.26 (4.656)	11.91 (0.469)	6.45 (0.254)	4.24 (0.167)	25.40 (1.000)	1.5 (0.06)	...
RX-31	134.54 (5.297)	11.91 (0.469)	6.45 (0.254)	4.24 (0.167)	25.40 (1.000)	1.5 (0.06)	...
RX-35	147.24 (5.797)	11.91 (0.469)	6.45 (0.254)	4.24 (0.167)	25.40 (1.000)	1.5 (0.06)	...
RX-37	159.94 (6.297)	11.91 (0.469)	6.45 (0.254)	4.24 (0.167)	25.40 (1.000)	1.5 (0.06)	...
RX-39	172.64 (6.797)	11.91 (0.469)	6.45 (0.254)	4.24 (0.167)	25.40 (1.000)	1.5 (0.06)	...
RX-41	191.69 (7.547)	11.91 (0.469)	6.45 (0.254)	4.24 (0.167)	25.40 (1.000)	1.5 (0.06)	...
RX-44	204.39 (8.047)	11.91 (0.469)	6.45 (0.254)	4.24 (0.167)	25.40 (1.000)	1.5 (0.06)	...
RX-45	221.84 (8.734)	11.91 (0.469)	6.45 (0.254)	4.24 (0.167)	25.40 (1.000)	1.5 (0.06)	...
RX-46	222.25 (8.750)	13.49 (0.531)	6.68 (0.263)	4.78 (0.188)	28.58 (1.125)	1.5 (0.06)	...
RX-47	245.26 (9.656)	19.84 (0.781)	10.34 (0.407)	6.88 (0.271)	41.28 (1.625)	2.3 (0.09)	...
RX-49	280.59 (11.047)	11.91 (0.469)	6.45 (0.254)	4.24 (0.167)	25.40 (1.000)	1.5 (0.06)	...
RX-50	283.36 (11.156)	16.66 (0.656)	8.51 (0.335)	5.28 (0.208)	31.75 (1.250)	1.5 (0.06)	...
RX-53	334.57 (13.172)	11.91 (0.469)	6.45 (0.254)	4.24 (0.167)	25.40 (1.000)	1.5 (0.06)	...
RX-54	337.34 (13.281)	16.66 (0.656)	8.51 (0.335)	5.28 (0.208)	31.75 (1.250)	1.5 (0.06)	...
RX-57	391.72 (15.422)	11.91 (0.469)	6.45 (0.254)	4.24 (0.167)	25.40 (1.000)	1.5 (0.06)	...
RX-63	441.73 (17.391)	27.00 (1.063)	14.78 (0.582)	8.46 (0.333)	50.80 (2.000)	2.3 (0.09)	...
RX-65	480.62 (18.922)	11.91 (0.469)	6.45 (0.254)	4.24 (0.167)	25.40 (1.000)	1.5 (0.06)	...
RX-66	483.39 (19.031)	16.66 (0.656)	8.51 (0.335)	5.28 (0.208)	31.75 (1.250)	1.5 (0.06)	...
RX-69	544.12 (21.422)	11.91 (0.469)	6.45 (0.254)	4.24 (0.167)	25.40 (1.000)	1.5 (0.06)	...
RX-70	550.06 (21.656)	19.84 (0.781)	10.34 (0.407)	6.88 (0.271)	41.28 (1.625)	2.3 (0.09)	...

**Table RJ-5-3  
Type RX Ring Gasket Dimensions and Tolerances (Cont'd)**

Ring Number	Outside Diameter of Ring, O.D., mm (in.)	Width of Ring, A, mm (in.)	Width of Flat, C, mm (in.)	Height of Outside Bevel, D, mm (in.)	Height of Ring, H, mm (in.)	Radius in Octagonal Ring, R <sub>1</sub> , mm (in.)	Hole Size, E, mm (in.) [Note (1)]
RX-73	596.11 (23.469)	13.49 (0.531)	6.68 (0.263)	5.28 (0.208)	31.75 (1.250)	1.5 (0.06)	...
RX-74	600.86 (23.656)	19.84 (0.781)	10.34 (0.407)	6.88 (0.271)	41.28 (1.625)	2.3 (0.09)	...
RX-82	67.87 (2.672)	11.91 (0.469)	6.45 (0.254)	4.24 (0.167)	25.40 (1.000)	1.5 (0.06)	1.5 (0.06)
RX-84	74.22 (2.922)	11.91 (0.469)	6.45 (0.254)	4.24 (0.167)	25.40 (1.000)	1.5 (0.06)	1.5 (0.06)
RX-85	90.09 (3.547)	13.49 (0.531)	6.68 (0.263)	4.24 (0.167)	25.40 (1.000)	1.5 (0.06)	1.5 (0.06)
RX-86	103.58 (4.078)	15.09 (0.594)	8.51 (0.335)	4.78 (0.188)	28.58 (1.125)	1.5 (0.06)	2.3 (0.09)
RX-87	113.11 (4.453)	15.09 (0.594)	8.51 (0.335)	4.78 (0.188)	28.58 (1.125)	1.5 (0.06)	2.3 (0.09)
RX-88	139.29 (5.484)	17.48 (0.688)	10.34 (0.407)	5.28 (0.208)	31.75 (1.250)	1.5 (0.06)	3.0 (0.12)
RX-89	129.77 (5.109)	18.26 (0.719)	10.34 (0.407)	5.28 (0.208)	31.75 (1.250)	1.5 (0.06)	3.0 (0.12)
RX-90	174.63 (6.875)	19.84 (0.781)	12.17 (0.479)	7.42 (0.292)	44.45 (1.750)	2.3 (0.09)	3.0 (0.12)
RX-91	286.94 (11.297)	30.18 (1.188)	19.81 (0.780)	7.54 (0.297)	45.24 (1.781)	2.3 (0.09)	3.0 (0.12)
RX-99	245.67 (9.672)	11.91 (0.469)	6.45 (0.254)	4.24 (0.167)	25.40 (1.000)	1.5 (0.06)	...
RX-201	51.46 (2.026)	5.74 (0.226)	3.20 (0.126)	1.45 (0.057)	11.30 (0.445)	0.5 (0.02) [Note (2)]	...
RX-205	62.31 (2.453)	5.56 (0.219)	3.05 (0.120)	1.83 (0.072) [Note (3)]	11.10 (0.437)	0.5 (0.02) [Note (2)]	...
RX-210	97.64 (3.844)	9.53 (0.375)	5.41 (0.213)	3.18 (0.125) [Note (3)]	19.05 (0.750)	0.8 (0.03) [Note (2)]	...
RX-215	140.89 (5.547)	11.91 (0.469)	5.33 (0.210)	4.24 (0.167) [Note (3)]	25.40 (1.000)	1.5 (0.06) [Note (2)]	...

## GENERAL NOTE: Tolerances:

23 deg = angle, ±0 deg, 30 min ( $\pm 1/2$  deg)

A = width of ring, +0.20 mm, -0.00 mm (+0.008 in., -0 in.)

Variation in width throughout the entire circumference of any ring shall not exceed 0.10 mm (0.004 in.) within these tolerances.

C = width of flat, +0.15 mm, -0.00 mm (+0.006 in., -0 in.)

D = height of outside bevel, +0.0 mm, -0.76 mm (+0 in., -0.030 in.)

E = hole size, ±0.5 mm (±0.02 in.)

H = height of ring, +0.20 mm, -0.00 mm (+0.008 in., -0 in.)

Variation in height throughout the entire circumference of any ring shall not exceed 0.10 mm (0.004 in.) within these tolerances.

O.D. = outside diameter of ring, +0.51 mm, -0.00 mm (+0.020 in., -0 in.)

R<sub>1</sub> = radius of ring, ±0.5 mm (±0.02 in.)

## NOTES:

- (1) Rings RX-82 through RX-91 require only one pressure passage hole as illustrated. The centerline of the hole shall be located at the midpoint of dimension C.
- (2) Tolerance on these dimensions is +0.5 mm, -0.0 mm (+0.02 in., -0 in.).
- (3) Tolerance on these dimensions is +0.00 mm, -0.38 mm (+0 in., -0.015 in.).

**Table RJ-5-4**  
**Pipe Sizes for Type RX Ring Gaskets Suitable for Referenced Standards**

Ring Number	Pipe Size, NPS, by API 6B Pressure Class			
	720-960 and 2000 [Note (1)]	2900 [Note (1)]	3000	5000
RX-20	1½	...	1½	1½
RX-23	2	...	...	...
RX-24	...	...	2	2
RX-25	...	...	...	3⅛
RX-26	2½	...	...	...
RX-27	...	...	2½	2½
RX-31	3	...	3	...
RX-35	...	...	...	3
RX-37	4	...	4	...
RX-39	...	...	...	4
RX-41	5	...	5	...
RX-44	...	...	...	5
RX-45	6	...	6	...
RX-46	...	...	...	6
RX-47	...	...	...	8 [Note (2)]
RX-49	8	...	8	...
RX-50	...	...	...	8
RX-53	10	...	10	...
RX-54	...	...	...	10
RX-57	12	...	12	...
RX-63	...	...	...	14
RX-65	16	...	...	...
RX-66	...	...	16	...
RX-69	18	...	...	...
RX-70	...	...	18	...
RX-73	20	...	...	...
RX-74	...	...	20	...
RX-82	...	1	...	...
RX-84	...	1½	...	...
RX-85	...	2	...	...
RX-86	...	2½	...	...
RX-87	...	3	...	...
RX-88	...	4	...	...
RX-89	...	3½	...	...
RX-90	...	5	...	...
RX-91	...	10	...	...
RX-99	8 [Note (2)]	...	8 [Note (2)]	...
RX-201	...	...	...	3⅛
RX-205	...	...	...	1⅓/16
RX-210	...	...	...	2⅑/16
RX-215	...	...	...	4⅒/16

## NOTES:

- (1) Class 720, 960, and 2900 flanges to API 6B are obsolete. Data are for information only.  
(2) Crossover flange connection.



**Table RJ-5-5  
Type BX Ring Gasket Dimensions and Tolerances**

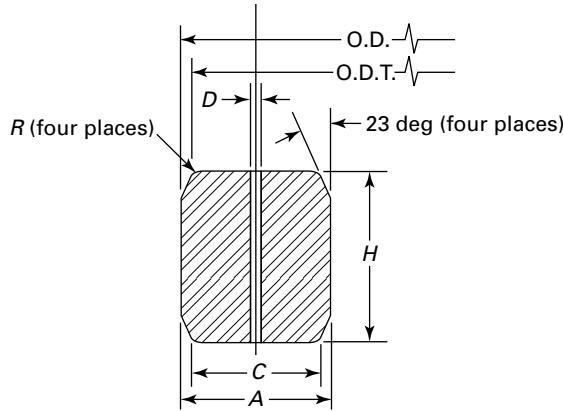

Ring Number	Nominal Size, mm (in.)	Outside Diameter of Ring, O.D., mm (in.)	Height of Ring, H, mm (in.)	Width of Ring, A, mm (in.)	Outside Diameter of Flat, O.D.T., mm (in.)	Width of Flat, C, mm (in.)	Hole Size, D, mm (in.) [Note (1)]
BX-150	43 (1 <sup>11</sup> / <sub>16</sub> )	72.19 (2.842)	9.30 (0.366)	9.30 (0.366)	70.87 (2.790)	7.98 (0.314)	1.5 (0.06)
BX-151	46 (1 <sup>13</sup> / <sub>16</sub> )	76.40 (3.008)	9.63 (0.379)	9.63 (0.379)	75.03 (2.954)	8.26 (0.325)	1.5 (0.06)
BX-152	52 (2 <sup>1</sup> / <sub>16</sub> )	84.68 (3.334)	10.24 (0.403)	10.24 (0.403)	83.24 (3.277)	8.79 (0.346)	1.5 (0.06)
BX-153	65 (2 <sup>9</sup> / <sub>16</sub> )	100.94 (3.974)	11.38 (0.448)	11.38 (0.448)	99.31 (3.910)	9.78 (0.385)	1.5 (0.06)
BX-154	78 (3 <sup>1</sup> / <sub>16</sub> )	116.84 (4.600)	12.40 (0.488)	12.40 (0.488)	115.09 (4.531)	10.64 (0.419)	1.5 (0.06)
BX-155	103 (4 <sup>1</sup> / <sub>16</sub> )	147.96 (5.825)	14.22 (0.560)	14.22 (0.560)	145.95 (5.746)	12.22 (0.481)	1.5 (0.06)
BX-156	179 (7 <sup>1</sup> / <sub>16</sub> )	237.92 (9.367)	18.62 (0.733)	18.62 (0.733)	235.28 (9.263)	15.98 (0.629)	3.0 (0.12)
BX-157	229 (9)	294.46 (11.593)	20.98 (0.826)	20.98 (0.826)	291.49 (11.476)	18.01 (0.709)	3.0 (0.12)
BX-158	279 (11)	352.04 (13.860)	23.14 (0.911)	23.14 (0.911)	348.77 (13.731)	19.86 (0.782)	3.0 (0.12)
BX-159	346 (13 <sup>5</sup> / <sub>8</sub> )	426.72 (16.800)	25.70 (1.012)	25.70 (1.012)	423.09 (16.657)	22.07 (0.869)	3.0 (0.12)
BX-160	346 (13 <sup>5</sup> / <sub>8</sub> )	402.59 (15.850)	23.83 (0.938)	13.74 (0.541)	399.21 (15.717)	10.36 (0.408)	3.0 (0.12)
BX-161	422 (16 <sup>5</sup> / <sub>8</sub> )	491.41 (19.347)	28.07 (1.105)	16.21 (0.638)	487.45 (19.191)	12.24 (0.482)	3.0 (0.12)
BX-162	422 (16 <sup>5</sup> / <sub>8</sub> )	475.49 (18.720)	14.22 (0.560)	14.22 (0.560)	473.48 (18.641)	12.22 (0.481)	1.5 (0.06)
BX-163	476 (18 <sup>3</sup> / <sub>4</sub> )	556.16 (21.896)	30.10 (1.185)	17.37 (0.684)	551.89 (21.728)	13.11 (0.516)	3.0 (0.12)
BX-164	476 (18 <sup>3</sup> / <sub>4</sub> )	570.56 (22.463)	30.10 (1.185)	24.59 (0.968)	566.29 (22.295)	20.32 (0.800)	3.0 (0.12)
BX-165	540 (21 <sup>1</sup> / <sub>4</sub> )	624.71 (24.595)	32.03 (1.261)	18.49 (0.728)	620.19 (24.417)	13.97 (0.550)	3.0 (0.12)
BX-166	540 (21 <sup>1</sup> / <sub>4</sub> )	640.03 (25.198)	32.03 (1.261)	26.14 (1.029)	635.51 (25.020)	21.62 (0.851)	3.0 (0.12)
BX-167	680 (26 <sup>3</sup> / <sub>4</sub> )	759.36 (29.896)	35.86 (1.412)	13.11 (0.516)	754.28 (29.696)	8.03 (0.316)	1.5 (0.06)
BX-168	680 (26 <sup>3</sup> / <sub>4</sub> )	765.25 (30.128)	35.86 (1.412)	16.05 (0.632)	760.17 (29.928)	10.97 (0.432)	1.5 (0.06)
BX-169	130 (5 <sup>1</sup> / <sub>8</sub> )	173.51 (6.831)	15.85 (0.624)	12.93 (0.509)	171.27 (6.743)	10.69 (0.421)	1.5 (0.06)
BX-170	168 (6 <sup>5</sup> / <sub>8</sub> )	218.03 (8.584)	14.22 (0.560)	14.22 (0.560)	216.03 (8.505)	12.22 (0.481)	1.5 (0.06)
BX-171	218 (8 <sup>9</sup> / <sub>16</sub> )	267.44 (10.529)	14.22 (0.560)	14.22 (0.560)	265.43 (10.450)	12.22 (0.481)	1.5 (0.06)
BX-172	283 (11 <sup>5</sup> / <sub>32</sub> )	333.07 (13.113)	14.22 (0.560)	14.22 (0.560)	331.06 (13.034)	12.22 (0.481)	1.5 (0.06)
BX-303	762 (30)	852.75 (33.573)	37.95 (1.494)	16.97 (0.668)	847.37 (33.361)	11.61 (0.457)	1.5 (0.06)

GENERAL NOTES:

(a) Radius, R, shall be 8% to 12% of the gasket height, H.

(b) Tolerances:

23 deg = angle, ±0 deg 15 min (±¼ deg)

A = width of ring, +0.20 mm, -0.00 mm (+0.008 in., -0 in.)

Variation in width throughout the entire circumference of any ring shall not exceed 0.10 mm (0.004 in.) within these tolerances.

C = width of flat, +0.15 mm, -0.00 mm (+0.006 in., -0 in.)

**Table RJ-5-5  
Type BX Ring Gasket Dimensions and Tolerances (Cont'd)**

GENERAL NOTES: (Cont'd)

 $D$  = hole size,  $\pm 0.5$  mm ( $\pm 0.02$  in.) $H$  = height of ring, +0.20 mm, -0.00 mm (+0.008 in., -0 in.)

Variation in height throughout the entire circumference of any ring shall not exceed 0.10 mm (0.004 in.) within these tolerances.

O.D. = outside diameter of ring, +0.00 mm, -0.15 mm (+0 in., -0.005 in.)

O.D.T. = outside diameter of flat,  $\pm 0.05$  mm ( $\pm 0.002$  in.) $R$  = radius of ring [see General Note (a)]NOTE: (1) One pressure passage hole is required per gasket as illustrated. The centerline of the hole shall be located at the midpoint of dimension  $C$ .

**Table RJ-5-6  
Pipe Sizes for Type BX Ring Gaskets Suitable for Referenced Standards**

Ring Number	Pipe Size, NPS, by API 6BX Pressure Class					
	2000	3000	5000	10000	15000	20000
BX-150	...	...	...	$1\frac{11}{16}$	$1\frac{11}{16}$	...
BX-151	...	...	...	$1\frac{13}{16}$	$1\frac{13}{16}$	$1\frac{13}{16}$
BX-152	...	...	...	$2\frac{1}{16}$	$2\frac{1}{16}$	$2\frac{1}{16}$
BX-153	...	...	...	$2\frac{9}{16}$	$2\frac{9}{16}$	$2\frac{9}{16}$
BX-154	...	...	...	$3\frac{1}{16}$	$3\frac{1}{16}$	$3\frac{1}{16}$
BX-155	...	...	...	$4\frac{1}{16}$	$4\frac{1}{16}$	$4\frac{1}{16}$
BX-156	...	...	...	$7\frac{1}{16}$	$7\frac{1}{16}$	$7\frac{1}{16}$
BX-157	...	...	...	9	9	9
BX-158	...	...	...	11	11	11
BX-159	...	...	...	$13\frac{5}{8}$	$13\frac{5}{8}$	$13\frac{5}{8}$
BX-160	...	...	$13\frac{5}{8}$	...	...	...
BX-161	...	...	$16\frac{3}{4}$	...	...	...
BX-162	...	...	$16\frac{3}{4}$	$16\frac{3}{4}$	$16\frac{3}{4}$	...
BX-163	...	...	$18\frac{3}{4}$	...	...	...
BX-164	...	...	...	$18\frac{3}{4}$	$18\frac{3}{4}$	...
BX-165	...	...	$21\frac{1}{4}$	...	...	...
BX-166	...	...	...	$21\frac{1}{4}$	...	...
BX-167	$26\frac{3}{4}$	...	...	...	...	...
BX-168	...	$26\frac{3}{4}$	...	...	...	...
BX-169	...	...	...	$5\frac{1}{8}$	...	...
BX-170	...	...	...	$6\frac{5}{8}$	$6\frac{5}{8}$	...
BX-171	...	...	...	$8\frac{9}{16}$	$8\frac{9}{16}$	...
BX-172	...	...	...	$11\frac{5}{32}$	$11\frac{5}{32}$	...
BX-303	30	30	...	...	...	...

# PART SW

## SPIRAL-WOUND GASKETS

### SW-1 SIZE AND CLASS

Spiral-wound gaskets, including centering ring and inner ring (paras. [SW-2.4](#) and [SW-2.5](#)), are identified by flange size (NPS), pressure class, and the appropriate flange standard (ASME B16.5 or ASME B16.47).

### SW-2 DIMENSIONS AND TOLERANCES

#### SW-2.1 General

Dimensions and tolerances for spiral-wound gaskets, centering rings, and inner rings shall be in accordance with [Figure SW-2.1-1](#) and [Tables SW-2.1-1](#) through [SW-2.1-6](#), and as specified in this Part.

#### SW-2.2 Construction

Spiral-wound gaskets shall be constructed as alternate plies (circular layers counted as revolutions) of preformed metal windings and pliant fillers that are spirally wound.

Pliant fillers shall not extend below the metal winding on both contact faces of the gasket. Metal winding thickness shall be  $0.190 \text{ mm} \pm 0.040 \text{ mm}$  ( $0.0075 \text{ in.} \pm 0.0015 \text{ in.}$ ). For all filler materials, filler thickness and density shall be determined by the manufacturer such that the performance testing criteria in [para. SW-2.6](#) will be met. In addition, for gaskets with flexible graphite filler material, filler thickness and density shall be determined by the manufacturer such that each finished gasket will compress to a thickness no less than  $3.43 \text{ mm}$  ( $0.135 \text{ in.}$ ) when subjected to the following uniform gasket stress, and where the gasket contact area is calculated using the inside and outside diameters as shown in [Tables SW-2.1-1](#) through [SW-2.1-3](#):

- (a) 52 MPa (7,500 psi) for Class 150 flanges
- (b) 70 MPa (10,000 psi) for Class 300 through Class 600 flanges
- (c) 140 MPa (20,000 psi) for Class 900 and above flanges

#### SW-2.3 Metal Joining

The inner windings shall have a minimum of three plies of preformed metal strip without filler. The initial two plies shall have spot welds spaced around the inner circumference. The minimum number of welds shall be three. The maximum distance between welds shall be

76 mm (3.0 in.). The outer windings, which shall have a minimum of three plies of preformed metal without filler, shall be spot-welded circumferentially with a minimum of three welds, the last of which shall be the terminal weld.

The distance of the first weld from the terminal weld shall be no greater than  $38 \text{ mm}$  ( $1.5 \text{ in.}$ ). Up to four additional loose preformed metal windings beyond the terminal weld may be used to retain the gasket into the centering ring.

#### SW-2.4 Centering Ring

All spiral-wound gaskets shall be furnished assembled into a centering ring. The centering-ring thickness shall be from  $2.97 \text{ mm}$  to  $3.33 \text{ mm}$  ( $0.117 \text{ in.}$  to  $0.131 \text{ in.}$ ) and suitably grooved on the inside diameter so as to retain the gasket.

#### SW-2.5 Inner Ring

(23)

Inward buckling of spiral-wound gaskets has been identified as a potential problem. Inner rings shall be furnished with all spiral-wound gaskets having polytetrafluoroethylene (PTFE) filler material. Inner rings for flexible graphite-filled, spiral-wound gaskets shall be furnished unless the purchaser specifies otherwise.

For all filler materials, inner rings shall be furnished in spiral-wound gaskets for

- (a) NPS 24 and larger in Class 900
- (b) NPS 12 and larger in Class 1500
- (c) NPS 4 and larger in Class 2500

Inner rings are required for these gaskets due to high available bolt loads, which may result in centering ring damage.

The inner-ring thickness shall be from  $2.97 \text{ mm}$  to  $3.33 \text{ mm}$  ( $0.117 \text{ in.}$  to  $0.131 \text{ in.}$ ).

[Tables SW-2.1-4](#) through [SW-2.1-6](#) show inner-ring inside diameters that may extend a maximum of  $1.5 \text{ mm}$  ( $0.06 \text{ in.}$ ) into the flange bore under the worst combination of flange bore, eccentric installation, and tolerance.

Gaskets with inner rings should be used only with socket welding, lapped, welding neck, and integral flanges. Reference [Table SW-2.5-1](#) for minimum pipewall thickness for use with gaskets with inner rings. Reference [Tables SW-2.5-2](#) through [SW-2.5-4](#) for maximum allowable bore for use with gaskets without inner rings.

**(23) SW-2.6 Performance Testing**

For all corresponding sizes and pressure classes, finished gaskets (including windings as well as inner and centering rings) shall be capable of meeting a maximum permissible leakage rate of 0.0137 mg/(s·m) [7.67 E-10 lb/(sec·in.)]. The circumferential length [meter (inch)] shall be calculated using the gasket outside diameter as shown in [Tables SW-2.1-1](#) through [SW-2.1-3](#). Testing shall be conducted at ambient temperature using an external calibration gas with a known methane concentration and a test gas flow rate of 1 L/min.

(a) The test fixture shall have a surface finish per ASME B16.5, be capable of shielding the gasket so as to direct any leakage to the monitoring probe, and be capable of applying a uniform load on the test gasket sealing element while internally pressurizing the gasket with methane (minimum 97% purity).

(b) Gasket stress to be maintained during the test load shall be 35 MPa (5,000 psi) for Class 150, 56 MPa (8,000 psi) for Class 300 and Class 400, and 70 MPa (10,000 psi) for Class 600 and above.

(c) Test pressure shall be 20 bar (290 psi) for Class 150 and 40 bar (580 psi) for Class 300 and above.

(d) Test pressure shall be maintained for a minimum of 4 h, after which time three readings shall be taken at approximately 5-min intervals; the average of these three readings shall be compared to the maximum permissible leakage rate.

**(23) SW-3 MATERIALS**

Spiral metallic winding materials shall be selected from [Table SW-3-1](#) or as agreed between the purchaser and manufacturer. Nonmetallic filler materials shall be in accordance with [Table SW-3-1](#). The inner-ring material should match the winding material unless the purchaser specifies otherwise. The centering ring may be carbon steel that is painted, metal plated, or otherwise coated to inhibit atmospheric corrosion.

**SW-4 MARKING****SW-4.1 General****(23)**

The centering ring of each spiral-wound gasket shall be permanently marked. The lettering height shall be a minimum of 2.5 mm (0.1 in.). The following information shall be included with the centering-ring markings:

(a) manufacturer's name or trademark.

(b) flange size (NPS).

(c) pressure class.

(d) winding metal abbreviation (see [Table SW-3-1](#)), except that the abbreviation may be omitted when Type 304 stainless steel is used.

(e) filler material abbreviation (see [Table SW-3-1](#)).

(f) centering- and inner-ring metal abbreviation (see [Table SW-3-1](#)), except that the abbreviation may be omitted when carbon steel is used for the centering ring and Type 304 stainless steel is used for the inner ring.

(g) flange identification. Gaskets intended for ASME B16.47 flanges shall be marked B16.47 A or B16.47 B, as applicable. Gaskets intended for ASME B16.5 flanges need not be so marked. Illustrative marking examples are shown in [Table SW-4.1-1](#).

(h) ASME B16.20 designation.

**SW-4.2 Pressure Class**

Gaskets suitable for more than one pressure class shall be marked with all applicable classes, as shown in [Table SW-4.1-1](#).

**SW-4.3 Color Coding**

Spiral-wound gaskets shall be marked with a color code that identifies the windings and filler materials. A continuous color around the outer edge of the centering ring shall identify the winding metal. The color identifying the filler material for NPS 1½ and larger shall have four intermittent stripes spaced approximately 90 deg apart on the outer edge of the centering ring. Smaller size gaskets shall have a minimum of two stripes 180 deg apart. The colors shall conform to those listed in [Table SW-3-1](#).

**Figure SW-2.1-1  
Spiral-Wound Gasket**

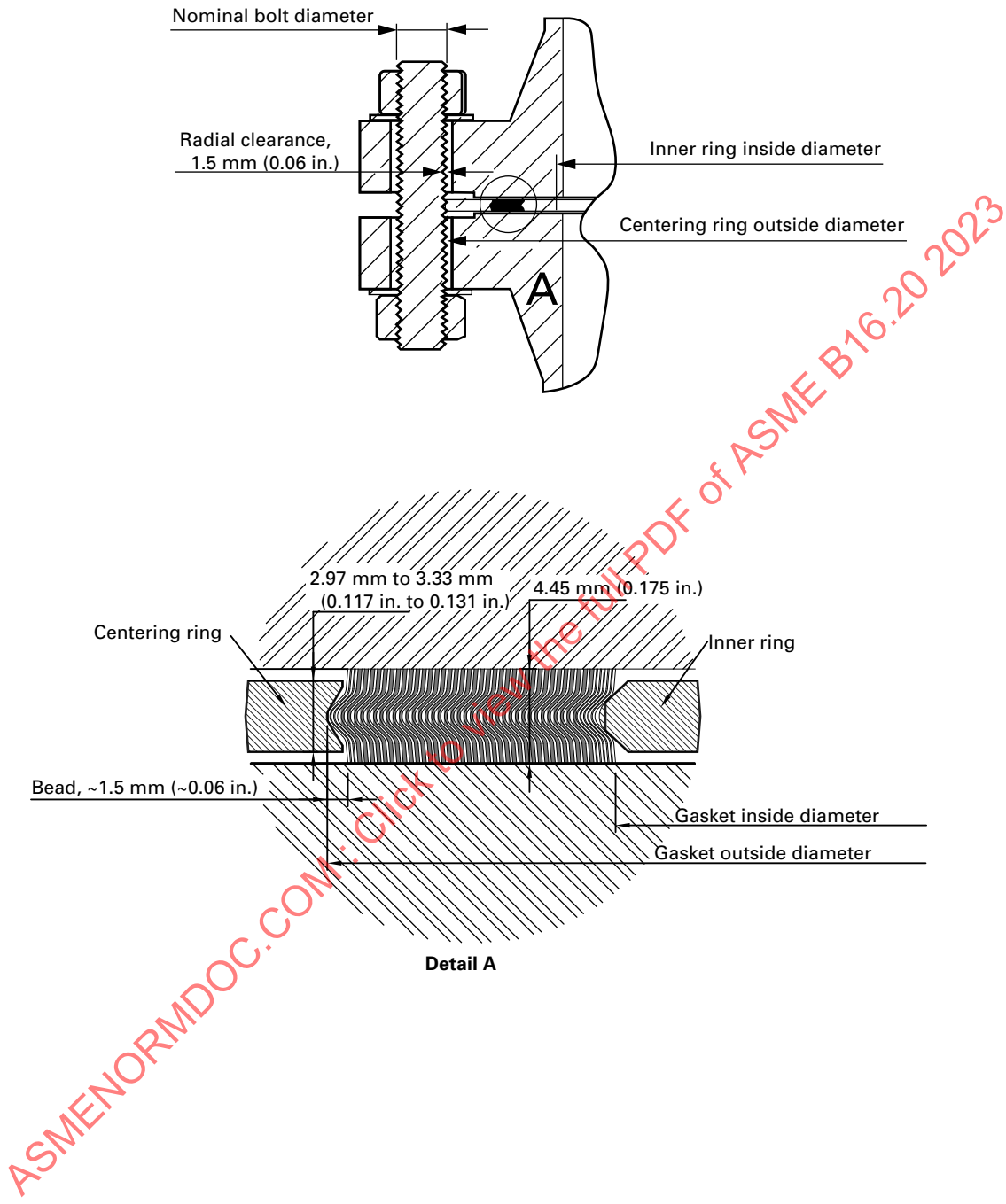

Table SW-2.1-1  
Dimensions for Spiral-Wound Gaskets Used With ASME B16.5 Flanges

Outside Diameter of Gasket [Note (1)]		SI Units, mm													
		Inside Diameter of Gasket by Class [Notes (2), (3)]						Outside Diameter of Centering Ring by Class [Note (4)]							
Flange Size (NPS)	Classes 900, 1500, 2500	150	300	400	600	900	1500	2500	150	300	400	600	900	1500	2500
		1/2	31.8	31.8	19.1	19.1	[Note (5)]	19.1	19.1	19.1	47.8	54.1	[Note (5)]	54.1	[Note (5)]
3/4	39.6	39.6	25.4	25.4	[Note (5)]	25.4	25.4	25.4	57.2	66.8	[Note (5)]	66.8	[Note (5)]	69.9	76.2
1	47.8	47.8	31.8	31.8	[Note (5)]	31.8	31.8	31.8	66.8	73.2	[Note (5)]	73.2	[Note (5)]	79.5	85.9
1 1/4	60.5	60.5	47.8	47.8	[Note (5)]	47.8	39.6	39.6	76.2	82.6	[Note (5)]	82.6	[Note (5)]	88.9	104.9
1 1/2	69.9	69.9	54.1	54.1	[Note (5)]	47.8	47.8	47.8	85.9	95.3	[Note (5)]	95.3	[Note (5)]	98.6	117.6
2	85.9	85.9	69.9	69.9	[Note (5)]	58.7	58.7	58.7	104.9	111.3	[Note (5)]	111.3	[Note (5)]	143.0	146.1
2 1/2	98.6	98.6	82.6	82.6	[Note (5)]	69.9	69.9	69.9	124.0	130.3	[Note (5)]	130.3	[Note (5)]	165.1	168.4
3	120.7	120.7	101.6	101.6	95.3	92.2	92.2	92.2	136.7	149.4	[Note (5)]	149.4	168.4	174.8	196.9
3 1/2	133.4	[Note (6)]	114.3	114.3	[Note (6)]	104.8	[Note (6)]	[Note (6)]	161.9	165.1	[Note (5)]	161.9	[Note (6)]	[Note (6)]	[Note (6)]
4	149.4	149.4	127.0	127.0	120.7	117.6	117.6	117.6	174.8	181.1	177.8	193.8	206.5	209.6	235.0
5	177.8	177.8	155.7	155.7	147.6	143.0	143.0	143.0	196.9	215.9	212.9	241.3	247.7	254.0	279.4
6	209.6	209.6	182.6	182.6	174.8	171.5	171.5	171.5	222.3	251.0	247.7	266.7	289.1	282.7	317.5
8	263.7	257.3	233.4	233.4	225.6	215.9	215.9	215.9	279.4	308.1	304.8	320.8	358.9	352.6	387.4
10	317.5	311.2	287.3	287.3	274.6	266.7	270.0	270.0	339.9	362.0	358.9	400.1	435.1	435.1	476.3
12	374.7	368.3	339.9	339.9	327.2	323.9	317.5	317.5	409.7	422.4	419.1	457.2	498.6	520.7	549.4
14	406.4	400.1	371.6	371.6	362.0	355.6	[Note (6)]	[Note (6)]	450.9	485.9	482.6	492.3	520.7	577.9	[Note (6)]
16	463.6	457.2	422.4	422.4	412.8	406.4	[Note (6)]	[Note (6)]	514.4	539.8	536.7	565.2	574.8	641.4	[Note (6)]
18	527.1	520.7	474.7	474.7	469.9	463.6	[Note (6)]	[Note (6)]	549.4	596.9	593.9	612.9	638.3	704.9	[Note (6)]
20	577.9	571.5	525.5	525.5	520.7	514.4	[Note (6)]	[Note (6)]	606.6	654.1	647.7	682.8	698.5	755.7	[Note (6)]
22	625.5	[Note (6)]	593.8	577.9	577.9	[Note (6)]	[Note (6)]	[Note (6)]	660.4	704.9	701.8	733.6	[Note (6)]	[Note (6)]	[Note (6)]
24	685.8	679.5	628.7	628.7	628.7	616.0	[Note (6)]	[Note (6)]	717.6	774.7	768.4	790.7	838.2	901.7	[Note (6)]

Table SW-2.1-1  
Dimensions for Spiral-Wound Gaskets Used With ASME B16.5 Flanges (Cont'd)

U.S. Customary Units, in.

Flange Size (NPS)	Outside Diameter of Gasket [Note (1)]		Inside Diameter of Gasket by Class [Notes (2), (3)]										Outside Diameter of Centering Ring by Class [Note (4)]				
	Classes 150, 300, 400, 600	Classes 900, 1500, 2500	150	300	400	600	900	1500	2500	150	300	400	600	900	1500	2500	
			0.75	0.75	[Note (5)]	0.75	[Note (5)]	0.75	0.75	0.75	1.88	2.13	[Note (5)]	2.13	[Note (5)]	2.50	2.75
1/2	1.25	1.25	0.75	0.75	[Note (5)]	0.75	[Note (5)]	0.75	0.75	2.25	2.63	[Note (5)]	2.63	[Note (5)]	2.75	3.00	
3/4	1.56	1.56	1.00	1.00	[Note (5)]	1.00	[Note (5)]	1.00	1.00	2.63	2.88	[Note (5)]	2.88	[Note (5)]	3.13	3.38	
1	1.88	1.88	1.25	1.25	[Note (5)]	1.25	[Note (5)]	1.25	1.25	3.00	3.25	[Note (5)]	3.25	[Note (5)]	3.50	4.13	
1 1/4	2.38	2.38	1.88	1.88	[Note (5)]	1.88	[Note (5)]	1.56	1.56	3.38	3.75	[Note (5)]	3.75	[Note (5)]	3.88	4.63	
1 1/2	2.75	2.75	2.13	2.13	[Note (5)]	2.13	[Note (5)]	1.88	1.88	4.13	4.38	[Note (5)]	4.38	[Note (5)]	5.63	5.75	
2	3.38	3.38	2.75	2.75	[Note (5)]	2.75	[Note (5)]	2.31	2.31	4.88	5.13	[Note (5)]	5.13	[Note (5)]	6.50	6.63	
2 1/2	3.88	3.88	3.25	3.25	[Note (5)]	3.25	[Note (5)]	2.75	2.75	5.38	5.88	[Note (5)]	5.88	[Note (5)]	6.88	7.75	
3	4.75	4.75	4.00	4.00	[Note (5)]	4.00	[Note (5)]	3.63	3.63	6.38	6.50	[Note (5)]	6.38	[Note (5)]	[Note (6)]	[Note (6)]	
3 1/2	5.25	[Note (6)]	4.50	4.50	[Note (5)]	4.13	[Note (6)]	[Note (6)]	[Note (6)]	6.88	7.13	7.00	7.63	8.13	8.25	9.25	
4	5.88	5.88	5.00	5.00	[Note (6)]	4.75	4.75	4.63	4.63	7.75	8.50	8.38	9.50	10.00	11.00		
5	7.00	7.00	6.13	6.13	[Note (6)]	5.81	5.81	5.63	5.63	8.75	9.88	9.75	10.50	11.38	12.50		
6	8.25	8.25	7.19	7.19	[Note (6)]	6.88	6.88	6.75	6.75	11.00	12.13	12.00	12.63	14.13	13.88	15.25	
8	10.38	10.13	9.19	9.19	[Note (6)]	8.88	8.88	8.50	8.50	13.38	14.25	14.13	15.75	17.13	17.13	18.75	
10	12.50	12.25	11.31	11.31	[Note (6)]	10.81	10.81	10.50	10.63	16.13	16.63	16.50	18.00	19.63	20.50	21.63	
12	14.75	14.50	13.38	13.38	[Note (6)]	12.88	12.88	12.75	12.50	17.75	19.13	19.00	19.38	20.50	22.75	[Note (6)]	
14	16.00	15.75	14.63	14.63	[Note (6)]	14.25	14.25	14.25	[Note (6)]	20.25	21.13	21.13	22.25	22.63	25.25	[Note (6)]	
16	18.25	18.00	16.63	16.63	[Note (6)]	16.25	16.25	16.00	[Note (6)]	23.50	23.38	23.38	24.13	25.13	27.75	[Note (6)]	
18	20.75	20.50	18.69	18.69	[Note (6)]	18.50	18.50	18.25	[Note (6)]	25.75	25.50	25.50	26.88	27.50	29.75	[Note (6)]	
20	22.75	22.50	20.69	20.69	[Note (6)]	20.50	20.50	20.25	[Note (6)]	27.75	27.63	27.63	28.88	[Note (6)]	[Note (6)]	[Note (6)]	
22	24.63	[Note (6)]	23.38	22.75	[Note (6)]	22.75	[Note (6)]	[Note (6)]	[Note (6)]	30.50	30.25	30.25	31.13	33.00	35.50	[Note (6)]	
24	27.00	26.75	24.75	24.75	[Note (6)]	24.75	24.75	24.25	[Note (6)]	32.75	32.75	32.75	33.00	35.50	38.00	[Note (6)]	

GENERAL NOTES:

- (a) For reference, see Figure SW-2.1-1.
- (b) The gasket thickness tolerance is ±0.13 mm (±0.005 in.) measured across the metallic portion of the gasket, not including the filler, which may protrude slightly beyond the metal.
- (c) For limitations on the maximum flange bore for use with these spiral-wound gaskets, see Table SW-2.5-2.

NOTES:

- (1) The gasket outside diameter tolerance for NPS 1/2 through NPS 8 is ±0.8 mm (±0.03 in.); for NPS 10 through NPS 24, +1.5 mm, -0.8 mm (+0.06 in., -0.03 in.).
- (2) Refer to para. SW-2.5 for required use of inner rings.

**Table SW-2.1-1**  
**Dimensions for Spiral-Wound Gaskets Used With ASME B16.5 Flanges (Cont'd)**

NOTES: (Cont'd)

- (3) The gasket inside diameter tolerance for NPS 8 is  $\pm 0.4$  mm ( $\pm 0.016$  in.); for NPS 10 through NPS 24,  $\pm 0.8$  mm ( $\pm 0.03$  in.).  
 (4) The centering-ring outside diameter tolerance is  $\pm 0.8$  mm ( $\pm 0.03$  in.).  
 (5) There are no sizes listed for Class 400 flanges in NPS  $\frac{1}{2}$  through NPS  $3\frac{1}{2}$  (use Class 600); Class 900 flanges in NPS  $\frac{1}{2}$  through NPS  $2\frac{1}{2}$  (use Class 1500).  
 (6) There are no flanges in NPS  $3\frac{1}{2}$  and NPS 22 in Class 900 and Class 1500; or Class 2500 flanges in NPS  $3\frac{1}{2}$  or NPS 14 and larger.

ASMEFORMDOC.COM : Click to view the full PDF of ASME B16.20 2023



**Table SW-2.1-2  
Dimensions for Spiral-Wound Gaskets Used With ASME B16.47 Series A Flanges**

SI Units, mm

Flange Size (NPS)	Class 150				Class 300				Class 400				Class 600				Class 900			
	Gasket		Centering-		Gasket		Centering-		Gasket		Centering-		Gasket		Centering-		Gasket		Centering-	
	Inside Diameter	Outside Diameter	Ring Outside Diameter	Ring Outside Diameter	Inside Diameter	Outside Diameter	Ring Outside Diameter	Ring Outside Diameter	Inside Diameter	Outside Diameter	Ring Outside Diameter	Ring Outside Diameter	Inside Diameter	Outside Diameter	Ring Outside Diameter	Ring Outside Diameter	Inside Diameter	Outside Diameter	Ring Outside Diameter	Ring Outside Diameter
26	673.1	704.9	774.7	[Note (4)]	685.8	736.6	835.2	[Note (4)]	685.8	736.6	831.9	[Note (4)]	685.8	736.6	866.9	[Note (4)]	685.8	736.6	882.7	[Note (4)]
28	723.9	755.7	831.9	[Note (4)]	736.6	787.4	898.7	[Note (4)]	736.6	787.4	892.3	[Note (4)]	736.6	787.4	914.4	[Note (4)]	736.6	787.4	946.2	[Note (4)]
30	774.7	806.5	882.7	[Note (4)]	793.8	844.6	952.5	[Note (4)]	793.8	844.6	946.2	[Note (4)]	793.8	844.6	971.6	[Note (4)]	793.8	844.6	1 009.7	[Note (4)]
32	825.5	860.6	939.8	[Note (4)]	850.9	901.7	1 006.6	[Note (4)]	850.9	901.7	1 003.3	[Note (4)]	850.9	901.7	1 022.4	[Note (4)]	850.9	901.7	1 073.2	[Note (4)]
34	876.3	911.4	990.6	[Note (4)]	901.7	952.5	1 057.4	[Note (4)]	901.7	952.5	1 054.1	[Note (4)]	901.7	952.5	1 073.2	[Note (4)]	901.7	952.5	1 136.7	[Note (4)]
36	927.1	968.5	1 047.8	[Note (4)]	955.8	1 006.6	1 117.6	[Note (4)]	955.8	1 006.6	1 117.6	[Note (4)]	955.8	1 006.6	1 130.3	[Note (4)]	958.9	1 009.7	1 200.2	[Note (4)]
38	977.9	1 019.3	1 111.3	[Note (4)]	977.9	1 016.0	1 054.1	[Note (4)]	971.6	1 022.4	1 073.2	[Note (4)]	990.6	1 041.4	1 104.9	[Note (4)]	1 035.1	1 085.9	1 200.2	[Note (4)]
40	1 028.7	1 070.1	1 162.1	[Note (4)]	1 022.4	1 070.1	1 114.6	[Note (4)]	1 025.7	1 076.5	1 127.3	[Note (4)]	1 047.8	1 098.6	1 155.7	[Note (4)]	1 098.6	1 149.4	1 251.0	[Note (4)]
42	1 079.5	1 124.0	1 219.2	[Note (4)]	1 073.2	1 120.9	1 165.4	[Note (4)]	1 076.5	1 127.3	1 178.1	[Note (4)]	1 104.9	1 155.7	1 219.2	[Note (4)]	1 149.4	1 200.2	1 301.8	[Note (4)]
44	1 130.3	1 178.1	1 276.4	[Note (4)]	1 130.3	1 181.1	1 219.2	[Note (4)]	1 180.3	1 181.1	1 231.9	[Note (4)]	1 162.1	1 212.9	1 270.0	[Note (4)]	1 206.5	1 257.3	1 368.6	[Note (4)]
46	1 181.1	1 228.9	1 327.2	[Note (4)]	1 178.1	1 228.9	1 273.3	[Note (4)]	1 193.8	1 244.6	1 289.1	[Note (4)]	1 212.9	1 263.7	1 327.2	[Note (4)]	1 270.0	1 320.8	1 435.1	[Note (4)]
48	1 231.9	1 279.7	1 384.3	[Note (4)]	1 235.2	1 286.0	1 324.1	[Note (4)]	1 244.6	1 295.4	1 346.2	[Note (4)]	1 270.0	1 320.8	1 390.7	[Note (4)]	1 320.8	1 371.6	1 485.9	[Note (4)]
50	1 282.7	1 333.5	1 435.1	[Note (4)]	1 295.4	1 346.2	1 378.0	[Note (4)]	1 295.4	1 346.2	1 403.4	[Note (4)]	1 320.8	1 371.6	1 447.8	[Note (4)]	[Note (5)]	[Note (5)]	[Note (5)]	[Note (5)]
52	1 333.5	1 384.3	1 492.3	[Note (4)]	1 346.2	1 397.0	1 428.8	[Note (4)]	1 346.2	1 397.0	1 454.2	[Note (4)]	1 371.6	1 422.4	1 498.6	[Note (4)]	[Note (5)]	[Note (5)]	[Note (5)]	[Note (5)]
54	1 384.3	1 435.1	1 549.4	[Note (4)]	1 403.4	1 454.2	1 492.3	[Note (4)]	1 403.4	1 454.2	1 517.7	[Note (4)]	1 428.8	1 479.6	1 555.8	[Note (4)]	[Note (5)]	[Note (5)]	[Note (5)]	[Note (5)]
56	1 435.1	1 485.9	1 606.6	[Note (4)]	1 454.2	1 505.0	1 543.1	[Note (4)]	1 454.2	1 505.0	1 568.5	[Note (4)]	1 479.6	1 530.4	1 612.9	[Note (4)]	[Note (5)]	[Note (5)]	[Note (5)]	[Note (5)]
58	1 485.9	1 536.7	1 663.7	[Note (4)]	1 511.3	1 562.1	1 593.9	[Note (4)]	1 505.0	1 555.8	1 619.3	[Note (4)]	1 536.7	1 587.5	1 663.7	[Note (4)]	[Note (5)]	[Note (5)]	[Note (5)]	[Note (5)]
60	1 536.7	1 587.5	1 714.5	[Note (4)]	1 562.1	1 612.9	1 644.7	[Note (4)]	1 568.5	1 619.3	1 682.8	[Note (4)]	1 593.9	1 644.7	1 733.6	[Note (4)]	[Note (5)]	[Note (5)]	[Note (5)]	[Note (5)]

Click to view the full PDF of ASME B16.20 2023

Table SW-2.1-2  
Dimensions for Spiral-Wound Gaskets Used With ASME B16.47 Series A Flanges (Cont'd)

Flange Size (NPS)	U.S. Customary Units, in.														
	Class 150			Class 300			Class 400			Class 600			Class 900		
	Gasket Inside Diameter	Centering-Ring Outside Diameter	Centering-Ring Outside Diameter	Gasket Inside Diameter	Centering-Ring Outside Diameter	Centering-Ring Outside Diameter	Gasket Inside Diameter	Centering-Ring Outside Diameter	Centering-Ring Outside Diameter	Gasket Inside Diameter	Centering-Ring Outside Diameter	Centering-Ring Outside Diameter	Gasket Inside Diameter	Centering-Ring Outside Diameter	Centering-Ring Outside Diameter
26	26.50	27.75	30.50	27.00	29.00	32.88	27.00	29.00	32.75	27.00	29.00	34.13	27.00	29.00	34.75
28	28.50	29.75	32.75	29.00	31.00	35.38	29.00	31.00	35.13	29.00	31.00	36.00	29.00	31.00	37.25
30	30.50	31.75	34.75	31.25	33.25	37.50	31.25	33.25	37.25	31.25	33.25	38.25	31.25	33.25	39.75
32	32.50	33.88	37.00	33.50	35.50	39.63	33.50	35.50	39.50	33.50	35.50	40.25	33.50	35.50	42.25
34	34.50	35.88	39.00	35.50	37.50	41.63	35.50	37.50	41.50	35.50	37.50	42.25	35.50	37.50	44.75
36	36.50	38.13	41.25	37.63	39.63	44.00	37.63	39.63	44.00	37.63	39.63	44.50	37.75	39.75	47.25
38	38.50	40.13	43.75	38.50	40.00	41.50	38.25	40.25	42.25	39.00	41.00	43.50	40.75	42.75	47.25
40	40.50	42.13	45.75	40.25	42.13	43.88	40.38	42.38	44.38	41.25	43.25	45.50	43.25	45.25	49.25
42	42.50	44.25	48.00	42.25	44.13	45.88	42.38	44.38	46.38	43.50	45.50	48.00	45.25	47.25	51.25
44	44.50	46.38	50.25	44.50	46.50	48.00	44.50	46.50	48.50	45.75	47.75	50.00	47.50	49.50	53.88
46	46.50	48.38	52.25	46.38	48.38	50.13	47.00	49.00	50.75	47.75	49.75	52.25	50.00	52.00	56.50
48	48.50	50.38	54.50	48.63	50.63	52.13	49.00	51.00	53.00	50.00	52.00	54.75	52.00	54.00	58.50
50	50.50	52.50	56.50	51.00	53.00	54.25	51.00	53.00	55.25	52.00	54.00	57.00	52.00	54.00	61.25
52	52.50	54.50	58.75	53.00	55.00	56.25	53.00	55.00	57.25	54.00	56.00	59.00	54.00	56.00	63.75
54	54.50	56.50	61.00	55.25	57.25	58.75	55.25	57.25	59.75	56.25	58.25	61.25	56.25	58.25	66.25
56	56.50	58.50	63.25	57.25	59.25	60.75	57.25	59.25	61.75	58.25	60.25	63.50	58.25	60.25	68.75
58	58.50	60.50	65.50	59.50	61.50	62.75	59.25	61.25	63.75	60.50	62.50	65.50	60.50	62.50	71.25
60	60.50	62.50	67.50	61.50	63.50	64.75	61.75	63.75	66.25	62.75	64.75	68.25	62.75	64.75	73.75

GENERAL NOTES:

- (a) For reference, see Figure SW-2.1-1.
- (b) The gasket thickness tolerance is  $\pm 0.13$  mm ( $\pm 0.005$  in.) measured across the metallic portion of the gasket, not including the filler, which may protrude slightly beyond the metal.
- (c) For limitations on the maximum flange bore for use with these spiral-wound gaskets, see Table SW-2.5-3.

NOTES:

- (1) Refer to para. SW-2.5 for required use of inner rings.
- (2) The gasket inside diameter tolerance for NPS 26 through NPS 34 is  $\pm 0.8$  mm ( $\pm 0.03$  in.), and the tolerance for NPS 36 through NPS 60 is  $\pm 1.5$  mm ( $\pm 0.06$  in.).
- (3) The gasket outside diameter tolerance for NPS 26 through NPS 60 is  $\pm 1.5$  mm ( $\pm 0.06$  in.).
- (4) The centering-ring outside diameter tolerance is  $\pm 0.8$  mm ( $\pm 0.03$  in.).
- (5) There are no Class 900 flanges in NPS 50 and larger.

**Table SW-2.1-3  
Dimensions for Spiral-Wound Gaskets Used With ASME B16.47 Series B Flanges**

SI Units, mm

Flange Size (NPS)	Class 150				Class 300				Class 400				Class 600				Class 900			
	Gasket		Centering-Ring		Gasket		Centering-Ring		Gasket		Centering-Ring		Gasket		Centering-Ring		Gasket		Centering-Ring	
	Inside Diameter	Outside Diameter	Ring Outside Diameter	Notes	Inside Diameter	Outside Diameter	Ring Outside Diameter	Notes	Inside Diameter	Outside Diameter	Ring Outside Diameter	Notes	Inside Diameter	Outside Diameter	Ring Outside Diameter	Notes	Inside Diameter	Outside Diameter	Ring Outside Diameter	Notes
26	673.1	698.5	725.4	[Note (4)]	673.1	711.2	771.7	[Note (4)]	666.8	698.5	746.3	[Note (4)]	663.7	714.5	765.3	[Note (4)]	692.2	749.3	838.2	[Note (4)]
28	723.9	749.3	776.2	[Note (4)]	723.9	762.0	825.5	[Note (4)]	714.5	749.3	800.1	[Note (4)]	704.9	755.7	819.2	[Note (4)]	743.0	800.1	901.7	[Note (4)]
30	774.7	800.1	827.0	[Note (4)]	774.7	812.8	886.0	[Note (4)]	765.3	806.5	857.3	[Note (4)]	778.0	828.8	879.6	[Note (4)]	806.5	857.3	958.9	[Note (4)]
32	825.5	850.9	881.1	[Note (4)]	825.5	863.6	939.8	[Note (4)]	812.8	860.6	911.4	[Note (4)]	831.9	882.7	933.5	[Note (4)]	863.6	914.4	1 016.0	[Note (4)]
34	876.3	908.1	935.0	[Note (4)]	876.3	914.4	993.9	[Note (4)]	866.9	911.4	962.2	[Note (4)]	889.0	939.8	997.0	[Note (4)]	920.8	971.6	1 073.2	[Note (4)]
36	927.1	958.9	987.6	[Note (4)]	927.1	965.2	1 047.8	[Note (4)]	917.7	965.2	1 022.4	[Note (4)]	939.8	990.6	1 047.8	[Note (4)]	946.2	997.0	1 124.0	[Note (4)]
38	974.9	1 009.7	1 044.7	[Note (4)]	1 009.7	1 047.8	1 098.6	[Note (4)]	971.6	1 022.4	1 073.2	[Note (4)]	990.6	1 041.4	1 104.9	[Note (4)]	1 035.1	1 085.9	1 200.2	[Note (4)]
40	1 022.4	1 063.8	1 095.5	[Note (4)]	1 060.5	1 098.6	1 149.4	[Note (4)]	1 025.7	1 076.5	1 127.3	[Note (4)]	1 047.8	1 098.6	1 155.7	[Note (4)]	1 098.6	1 149.4	1 251.0	[Note (4)]
42	1 079.5	1 114.6	1 146.3	[Note (4)]	1 111.3	1 149.4	1 200.2	[Note (4)]	1 076.5	1 127.3	1 178.1	[Note (4)]	1 104.9	1 155.7	1 219.2	[Note (4)]	1 149.4	1 200.2	1 301.8	[Note (4)]
44	1 124.0	1 165.4	1 197.1	[Note (4)]	1 162.1	1 200.2	1 251.0	[Note (4)]	1 130.3	1 181.1	1 231.9	[Note (4)]	1 162.1	1 212.9	1 270.0	[Note (4)]	1 206.5	1 257.3	1 368.6	[Note (4)]
46	1 181.1	1 224.0	1 255.8	[Note (4)]	1 216.2	1 254.3	1 317.8	[Note (4)]	1 193.8	1 244.6	1 289.1	[Note (4)]	1 212.9	1 263.7	1 327.2	[Note (4)]	1 270.0	1 320.8	1 435.1	[Note (4)]
48	1 231.9	1 270.0	1 306.6	[Note (4)]	1 263.7	1 311.4	1 368.6	[Note (4)]	1 244.6	1 295.4	1 346.2	[Note (4)]	1 270.0	1 320.8	1 390.7	[Note (4)]	1 320.8	1 371.6	1 485.9	[Note (4)]
50	1 282.7	1 325.6	1 357.4	[Note (4)]	1 317.8	1 355.9	1 419.4	[Note (4)]	1 295.4	1 346.2	1 403.4	[Note (4)]	1 320.8	1 371.6	1 447.8	[Note (4)]	[Note (5)]	[Note (5)]	[Note (5)]	[Note (5)]
52	1 333.5	1 376.4	1 408.2	[Note (4)]	1 368.6	1 406.7	1 470.2	[Note (4)]	1 346.2	1 397.0	1 454.2	[Note (4)]	1 371.6	1 422.4	1 498.6	[Note (4)]	[Note (5)]	[Note (5)]	[Note (5)]	[Note (5)]
54	1 384.3	1 422.4	1 463.8	[Note (4)]	1 403.4	1 454.2	1 530.4	[Note (4)]	1 403.4	1 454.2	1 517.7	[Note (4)]	1 428.8	1 479.6	1 555.8	[Note (4)]	[Note (5)]	[Note (5)]	[Note (5)]	[Note (5)]
56	1 444.8	1 478.0	1 514.6	[Note (4)]	1 479.6	1 524.0	1 593.9	[Note (4)]	1 454.2	1 505.0	1 568.5	[Note (4)]	1 479.6	1 530.4	1 612.9	[Note (4)]	[Note (5)]	[Note (5)]	[Note (5)]	[Note (5)]
58	1 500.1	1 528.8	1 579.6	[Note (4)]	1 535.2	1 573.3	1 655.8	[Note (4)]	1 505.0	1 555.8	1 619.3	[Note (4)]	1 536.7	1 587.5	1 663.7	[Note (4)]	[Note (5)]	[Note (5)]	[Note (5)]	[Note (5)]
60	1 557.3	1 586.0	1 630.4	[Note (4)]	1 589.0	1 630.4	1 706.6	[Note (4)]	1 568.5	1 619.3	1 682.8	[Note (4)]	1 593.9	1 644.7	1 733.6	[Note (4)]	[Note (5)]	[Note (5)]	[Note (5)]	[Note (5)]

Click to view the full PDF of ASME B16.20 2023

Table SW-2.1-3  
Dimensions for Spiral-Wound Gaskets Used With ASME B16.47 Series B Flanges (Cont'd)

Flange Size (NPS)	U.S. Customary Units, in.														
	Class 150			Class 300			Class 400			Class 600			Class 900		
	Inside Diameter [Notes (1), (2)]	Outside Diameter [Note (3)]	Centering-Ring Outside Diameter [Note (4)]	Inside Diameter [Notes (1), (2)]	Outside Diameter [Note (3)]	Centering-Ring Outside Diameter [Note (4)]	Inside Diameter [Notes (1), (2)]	Outside Diameter [Note (3)]	Centering-Ring Outside Diameter [Note (4)]	Inside Diameter [Notes (1), (2)]	Outside Diameter [Note (3)]	Centering-Ring Outside Diameter [Note (4)]	Inside Diameter [Notes (1), (2)]	Outside Diameter [Note (3)]	Centering-Ring Outside Diameter [Note (4)]
26	26.50	27.50	28.56	26.50	28.00	30.38	26.25	27.50	29.38	26.13	28.13	30.13	27.25	29.50	33.00
28	28.50	29.50	30.56	28.50	30.00	32.50	28.13	29.50	31.50	27.75	29.75	32.25	29.25	31.50	35.50
30	30.50	31.50	32.56	30.50	32.00	34.88	30.13	31.75	33.75	30.63	32.63	34.63	31.75	33.75	37.75
32	32.50	33.50	34.69	32.50	34.00	37.00	32.00	33.88	35.88	32.75	34.75	36.75	34.00	36.00	40.00
34	34.50	35.75	36.81	34.50	36.00	39.13	34.13	35.88	37.88	35.00	37.00	39.25	36.25	38.25	42.25
36	36.50	37.75	38.88	36.50	38.00	41.25	36.13	38.00	40.25	37.00	39.00	41.25	37.25	39.25	44.25
38	38.38	39.75	41.13	39.75	41.25	43.25	38.25	40.25	42.25	39.00	41.00	43.50	40.75	42.75	47.25
40	40.25	41.88	43.13	41.75	43.25	45.25	40.38	42.38	44.38	41.25	43.25	45.50	43.25	45.25	49.25
42	42.50	43.88	45.13	43.75	45.25	47.25	42.38	44.38	46.38	43.50	45.50	48.00	45.25	47.25	51.25
44	44.25	45.88	47.13	45.75	47.25	49.25	44.50	46.50	48.50	45.75	47.75	50.00	47.50	49.50	53.88
46	46.50	48.19	49.44	47.88	49.38	51.88	47.00	49.00	50.75	47.75	49.75	52.25	50.00	52.00	56.50
48	48.50	50.00	51.44	49.75	51.63	53.88	49.00	51.00	53.00	50.00	52.00	54.75	52.00	54.00	58.50
50	50.50	52.19	53.44	51.88	53.38	55.88	51.00	53.00	55.25	52.00	54.00	57.00	54.00	56.00	61.00
52	52.50	54.19	55.44	53.88	55.38	57.88	53.00	55.00	57.25	54.00	56.00	59.00	56.00	58.00	63.00
54	54.50	56.00	57.63	55.25	57.25	60.25	55.25	57.25	59.75	56.25	58.25	61.25	58.25	60.25	65.00
56	56.88	58.19	59.63	58.25	60.00	62.75	57.25	59.25	61.75	58.25	60.25	63.50	60.25	62.25	67.00
58	59.06	60.19	62.19	60.44	61.94	65.19	59.25	61.25	63.75	60.50	62.50	65.50	62.50	64.50	69.00
60	61.31	62.44	64.19	62.56	64.19	67.19	61.75	63.75	66.25	62.75	64.75	68.25	64.75	66.75	71.00

GENERAL NOTES:

- (a) For reference, see Figure SW-2.1-1.
- (b) The gasket thickness tolerance is  $\pm 0.13$  mm ( $\pm 0.005$  in.) measured across the metallic portion of the gasket, not including the filler, which may protrude slightly beyond the metal.
- (c) For limitations on the maximum flange bore for use with these spiral-wound gaskets, see Table SW-2.5-4.

NOTES:

- (1) Refer to para. SW-2.5 for required use of inner rings.
- (2) The gasket inside diameter tolerance for NPS 26 through NPS 34 is  $\pm 0.8$  mm ( $\pm 0.03$  in.), and the tolerance for NPS 36 through NPS 60 is  $\pm 1.5$  mm ( $\pm 0.06$  in.).
- (3) The gasket outside diameter tolerance for NPS 26 through NPS 60 is  $\pm 1.5$  mm ( $\pm 0.06$  in.).
- (4) The centering-ring outside diameter tolerance is  $\pm 0.8$  mm ( $\pm 0.03$  in.).
- (5) There are no Class 900 flanges in NPS 50 and larger.

(23) **Table SW-2.1-4**  
**Inside Diameters of Inner Rings for Spiral-Wound Gaskets for Use With ASME B16.5 Flanges**

Flange Size (NPS)	Inside Diameter of Inner Ring by Pressure Class, mm (in.)						
	150	300	400	600	900	1500	2500
1/2	14.2 (0.56)	14.2 (0.56)	[Note (1)]	14.2 (0.56)	[Note (1)]	14.2 (0.56)	14.2 (0.56)
3/4	20.6 (0.81)	20.6 (0.81)	[Note (1)]	20.6 (0.81)	[Note (1)]	20.6 (0.81)	20.6 (0.81)
1	26.9 (1.06)	26.9 (1.06)	[Note (1)]	26.9 (1.06)	[Note (1)]	26.9 (1.06)	26.9 (1.06)
1 1/4	38.1 (1.50)	38.1 (1.50)	[Note (1)]	38.1 (1.50)	[Note (1)]	33.3 (1.31)	33.3 (1.31)
1 1/2	44.5 (1.75)	44.5 (1.75)	[Note (1)]	44.5 (1.75)	[Note (1)]	41.4 (1.63)	41.4 (1.63)
2	55.6 (2.19)	55.6 (2.19)	[Note (1)]	55.6 (2.19)	[Note (1)]	52.3 (2.06)	52.3 (2.06)
2 1/2	66.5 (2.62)	66.5 (2.62)	[Note (1)]	66.5 (2.62)	[Note (1)]	63.5 (2.50)	63.5 (2.50)
3	81.0 (3.19)	81.0 (3.19)	[Note (1)]	81.0 (3.19)	78.7 (3.10)	78.7 (3.10)	78.7 (3.10)
3 1/2	101.1 (3.98)	101.1 (3.98)	[Note (1)]	91.4 (3.60)	[Note (2)]	[Note (2)]	[Note (2)]
4	106.4 (4.19)	106.4 (4.19)	102.6 (4.04)	102.6 (4.04)	102.6 (4.04)	97.8 (3.85)	97.8 (3.85)
5	131.8 (5.19)	131.8 (5.19)	128.3 (5.05)	128.3 (5.05)	128.3 (5.05)	124.5 (4.90)	124.5 (4.90)
6	157.2 (6.19)	157.2 (6.19)	154.9 (6.10)	154.9 (6.10)	154.9 (6.10)	147.3 (5.80)	147.3 (5.80)
8	215.9 (8.50)	215.9 (8.50)	205.7 (8.10)	205.7 (8.10)	196.9 (7.75)	196.9 (7.75)	196.9 (7.75)
10	268.2 (10.56)	268.2 (10.56)	255.3 (10.05)	255.3 (10.05)	246.1 (9.69)	246.1 (9.69)	246.1 (9.69)
12	317.5 (12.50)	317.5 (12.50)	307.3 (12.10)	307.3 (12.10)	292.1 (11.50)	292.1 (11.50)	292.1 (11.50)
14	349.3 (13.75)	349.3 (13.75)	342.9 (13.50)	342.9 (13.50)	320.8 (12.63)	320.8 (12.63)	[Note (2)]
16	400.1 (15.75)	400.1 (15.75)	389.9 (15.35)	389.9 (15.35)	374.7 (14.75)	368.3 (14.50)	[Note (2)]
18	449.3 (17.69)	449.3 (17.69)	438.2 (17.25)	438.2 (17.25)	425.5 (16.75)	425.5 (16.75)	[Note (2)]
20	500.1 (19.69)	500.1 (19.69)	489.0 (19.25)	489.0 (19.25)	482.6 (19.00)	476.3 (18.75)	[Note (2)]
22	568.4 (22.38)	552.5 (21.75)	546.2 (21.50)	546.2 (21.50)	[Note (2)]	[Note (2)]	[Note (2)]
24	603.3 (23.75)	603.3 (23.75)	590.6 (23.25)	590.6 (23.25)	590.6 (23.25)	577.9 (22.75)	[Note (2)]

## GENERAL NOTES:

- (a) The inner-ring thickness shall be 2.97 mm to 3.33 mm (0.117 in. to 0.131 in.).  
 (b) For sizes NPS 1/2 through NPS 3, the inside diameter tolerance is  $\pm 0.8$  mm ( $\pm 0.03$  in.); for larger sizes, the inside diameter tolerance is  $\pm 1.5$  mm ( $\pm 0.06$  in.). See [Table SW-2.5-1](#) for minimum pipe wall thicknesses that are suitable for use with standard inner rings.  
 (c) Refer to [para. SW-2.5](#) for required use of inner rings.

## NOTES:

- (1) There are no sizes listed for Class 400 flanges in NPS 1/2 through NPS 3 1/2 (use Class 600); Class 900 flanges in NPS 1/2 through NPS 2 1/2 (use Class 1500).  
 (2) There are no flanges in NPS 3 1/2 and NPS 22 in Class 900 and Class 1500; or Class 2500 flanges in NPS 3 1/2 or NPS 14 and larger.

**Table SW-2.1-5**  
**Inside Diameters of Inner Rings for Spiral-Wound Gaskets Used Between ASME B16.47 Series A Flanges**

Flange Size (NPS)	Inside Diameter of Inner Ring by Pressure Class, mm (in.)				
	150	300	400	600	900
26	654.1 (25.75)	654.1 (25.75)	660.4 (26.00)	647.7 (25.50)	660.4 (26.00)
28	704.9 (27.75)	704.9 (27.75)	711.2 (28.00)	698.5 (27.50)	711.2 (28.00)
30	755.7 (29.75)	755.7 (29.75)	755.7 (29.75)	755.7 (29.75)	768.4 (30.25)
32	806.5 (31.75)	806.5 (31.75)	812.8 (32.00)	812.8 (32.00)	812.8 (32.00)
34	857.3 (33.75)	857.3 (33.75)	863.6 (34.00)	863.6 (34.00)	863.6 (34.00)
36	908.1 (35.75)	908.1 (35.75)	917.7 (36.13)	917.7 (36.13)	920.8 (36.25)
38	958.9 (37.75)	952.5 (37.50)	952.5 (37.50)	952.5 (37.50)	1 009.7 (39.75)
40	1 009.7 (39.75)	1 003.3 (39.50)	1 000.3 (39.38)	1 009.7 (39.75)	1 060.5 (41.75)
42	1 060.5 (41.75)	1 054.1 (41.50)	1 051.1 (41.38)	1 066.8 (42.00)	1 111.3 (43.75)
44	1 111.3 (43.75)	1 104.9 (43.50)	1 104.9 (43.50)	1 111.3 (43.75)	1 155.7 (45.50)
46	1 162.1 (45.75)	1 152.7 (45.38)	1 168.4 (46.00)	1 162.1 (45.75)	1 219.2 (48.00)
48	1 212.9 (47.75)	1 209.8 (47.63)	1 206.5 (47.50)	1 219.2 (48.00)	1 270.0 (50.00)
50	1 263.7 (49.75)	1 244.6 (49.00)	1 257.3 (49.50)	1 270.0 (50.00)	[Note (1)]
52	1 314.5 (51.75)	1 320.8 (52.00)	1 308.1 (51.50)	1 320.8 (52.00)	[Note (1)]
54	1 358.9 (53.50)	1 352.6 (53.25)	1 352.6 (53.25)	1 378.0 (54.25)	[Note (1)]
56	1 409.7 (55.50)	1 403.4 (55.25)	1 403.4 (55.25)	1 428.8 (56.25)	[Note (1)]
58	1 460.5 (57.50)	1 447.8 (57.00)	1 454.2 (57.25)	1 473.2 (58.00)	[Note (1)]
60	1 511.3 (59.50)	1 524.0 (60.00)	1 517.7 (59.75)	1 530.4 (60.25)	[Note (1)]

## GENERAL NOTES:

- (a) The inner-ring thickness shall be 2.97 mm to 3.33 mm (0.117 in. to 0.131 in.).  
 (b) The inside diameter tolerance is  $\pm 3.0$  mm ( $\pm 0.12$  in.).  
 (c) These inner rings are suitable for use with pipe walls 9.53 mm (0.38 in.) or thicker.  
 (d) Refer to [para. SW-2.5](#) for required use of inner rings.

NOTE: (1) There are no Class 900 flanges in NPS 50 and larger.

**Table SW-2.1-6**  
**Inside Diameters of Inner Rings for Spiral-Wound Gaskets Used Between ASME B16.47 Series B Flanges**

Flange Size (NPS)	Inside Diameter of Inner Ring by Pressure Class, mm (in.)				
	150	300	400	600	900
26	654.1 (25.75)	654.1 (25.75)	654.1 (25.75)	644.7 (25.38)	666.8 (26.25)
28	704.9 (27.75)	704.9 (27.75)	701.8 (27.63)	685.8 (27.00)	717.6 (28.25)
30	755.7 (29.75)	755.7 (29.75)	752.6 (29.63)	752.6 (29.63)	781.1 (30.75)
32	806.5 (31.75)	806.5 (31.75)	800.1 (31.50)	793.8 (31.25)	838.2 (33.00)
34	857.3 (33.75)	857.3 (33.75)	850.9 (33.50)	850.9 (33.50)	895.4 (35.25)
36	908.1 (35.75)	908.1 (35.75)	898.7 (35.38)	901.7 (35.50)	920.8 (36.25)
38	958.9 (37.75)	971.6 (38.25)	952.5 (37.50)	952.5 (37.50)	1 009.7 (39.75)
40	1 009.7 (39.75)	1 022.4 (40.25)	1 000.3 (39.38)	1 009.7 (39.75)	1 060.5 (41.75)
42	1 060.5 (41.75)	1 085.9 (42.75)	1 051.1 (41.38)	1 066.8 (42.00)	1 111.3 (43.75)
44	1 111.3 (43.75)	1 124.0 (44.25)	1 104.9 (43.50)	1 111.3 (43.75)	1 155.7 (45.50)
46	1 162.1 (45.75)	1 178.1 (46.38)	1 168.4 (46.00)	1 162.1 (45.75)	1 219.2 (48.00)
48	1 212.9 (47.75)	1 231.9 (48.50)	1 206.5 (47.50)	1 219.2 (48.00)	1 270.0 (50.00)
50	1 263.7 (49.75)	1 267.0 (49.88)	1 257.3 (49.50)	1 270.0 (50.00)	[Note (1)]
52	1 314.5 (51.75)	1 317.8 (51.88)	1 308.1 (51.50)	1 320.8 (52.00)	[Note (1)]
54	1 365.3 (53.75)	1 365.3 (53.75)	1 352.6 (53.25)	1 378.0 (54.25)	[Note (1)]
56	1 422.4 (56.00)	1 428.8 (56.25)	1 403.4 (55.25)	1 428.8 (56.25)	[Note (1)]
58	1 478.0 (58.19)	1 484.4 (58.44)	1 454.2 (57.25)	1 473.2 (58.00)	[Note (1)]
60	1 535.2 (60.44)	1 557.3 (61.31)	1 517.7 (59.75)	1 530.4 (60.25)	[Note (1)]

## GENERAL NOTES:

- (a) The inner-ring thickness shall be 2.97 mm to 3.33 mm (0.117 in. to 0.131 in.).  
 (b) The inside diameter tolerance is  $\pm 3.0$  mm ( $\pm 0.12$  in.).  
 (c) These inner rings are suitable for use with pipe walls 9.53 mm (0.375 in.) or thicker.  
 (d) Refer to [para. SW-2.5](#) for required use of inner rings.

NOTE: (1) There are no Class 900 flanges in NPS 50 and larger.

**Table SW-2.5-1  
Minimum Pipe Wall Thickness Suitable for Use of Spiral-Wound Gaskets With Inner Rings  
for ASME B16.5 Flanges**

(23)

Flange Size (NPS)	Minimum Pipe Wall Thickness by Pressure Class											
	150	300	400	600	900	1500	2500					
1/2	Schedule 80											
3/4												
1												
1 1/4	Schedule 40											
1 1/2												
2												
2 1/2												
3												
3 1/2	Schedule 80											
4												
5												
6	Schedule 10S											
8												
10												
12												
14												
16							Schedule 30		Schedule 80		No flanges	
18												
20												
22												
24												

GENERAL NOTES:

- (a) The pipe wall schedules identified represent the minimum recommended pipe wall thickness suitable for use with inner rings for ASME B16.5 flanges. (Reference ASME B36.10M and ASME B36.19M.)
- (b) Gaskets with inner rings should be used only with socket welding, lapped, welding neck, and integral flanges.
- (c) Refer to para. SW-2.5 for required use of inner rings.

ASMENORMDOC.COM : Click to view the full PDF of ASME B16.20 2023



**Table SW-2.5-2  
Maximum Bore of ASME B16.5 Flanges for Use With Spiral-Wound Gaskets**

Flange Size (NPS)	Maximum Bore by Pressure Class							
	75	150	300	400	600	900 [Note (1)]	1500 [Note (1)]	2500 [Note (1)]
1/2	No flanges	WN flange only [Note (2)]	SO flange [Note (3)] WN flange [Note (2)]	Use Class 600 dimensions	WN flange only [Note (2)]	Use Class 1500 dimensions	WN flange only [Note (2)]	
3/4					SO flange [Note (3)]			
1					WN flange [Note (2)]			
1 1/4					SO flange [Note (3)]			
1 1/2	No flanges	WN flange, any bore	SO flange [Note (3)]	WN flange, any bore	SO flange [Note (3)]	WN flange with Schedule 10S bore described in ASME B36.19M [includes nozzle [Note (4)] but excludes SO flange]	WN flange with SW bore [includes nozzle [Note (4)] but excludes SO flange]	
2					WN flange, any bore			
2 1/2	No flanges	SO flange WN flange, any bore	WN flange with Schedule 10S bore described in ASME B36.19M [includes nozzle [Note (4)] but excludes SO flange]	WN flange, any bore	SO flange [Note (3)]	WN flange with Schedule 10S bore described in ASME B36.19M [includes nozzle [Note (4)] but excludes SO flange]	WN flange with SW bore [includes nozzle [Note (4)] but excludes SO flange]	
3					WN flange, any bore			
3 1/2								
4								
6	No flanges	SO flange WN flange, any bore	WN flange with Schedule 10S bore described in ASME B36.19M [includes nozzle [Note (4)] but excludes SO flange]	WN flange, any bore	WN flange with Schedule 10S bore described in ASME B36.19M [includes nozzle [Note (4)] but excludes SO flange]	WN flange with Schedule 10S bore described in ASME B36.19M [excludes nozzle [Note (4)] and SO flange] [Note (5)]	WN flange with Schedule 80 bore [excludes nozzle [Note (4)] and SO flange] [Note (5)]	No flanges
8								
10								
12								
14								
16								
18								
20								
22								
24								

**GENERAL NOTES:**

- (a) This table shows the maximum bore of flanges for which the spiral-wound gasket dimensions shown in Table SW-2.1-1 are recommended, considering the tolerances involved, possible eccentric installation, and the possibility that the gasket may extend into the assembled flange bore.
- (b) For maximum permissible flange bores for nonmandatory inner rings, see Table SW-2.5-1.
- (c) Abbreviations: SO = slip on and threaded, WN = welding neck, and SW = standard wall.

**NOTES:**

- (1) Refer to para. SW-2.5 for required use of inner rings. These inner rings may extend into the pipe bore a maximum of 1.5 mm (0.06 in.) under the worst combination of maximum bore, eccentric installation, and additive tolerances.
- (2) In these sizes, the gasket is suitable for a welding neck flange with a standard wall bore, if the gasket and flanges are assembled concentrically. This also applies to a nozzle. It is the user's responsibility to determine if the gasket is satisfactory for a flange of any larger bore.
- (3) Gaskets in these sizes are suitable for slip-on flanges only if the gaskets and flanges are assembled concentrically.
- (4) A nozzle is a long welding neck; the bore equals the flange NPS.
- (5) An NPS 24 gasket is suitable for nozzles.

**Table SW-2.5-3**  
**Maximum Bore of ASME B16.47 Series A Flanges for Use With Spiral-Wound Gaskets**

Flange Size (NPS)	Maximum Bore by Pressure Class				
	150	300	400	600	900
26	[Note (1)]	[Note (2)]	[Note (2)]	[Note (2)]	[Note (2)]
28	[Note (1)]	[Note (2)]	[Note (2)]	[Note (2)]	[Note (2)]
30	[Note (1)]	[Note (2)]	[Note (2)]	[Note (2)]	[Note (2)]
32	[Note (1)]	[Note (2)]	[Note (2)]	[Note (2)]	[Note (2)]
34	[Note (1)]	[Note (2)]	[Note (2)]	[Note (2)]	[Note (2)]
36	[Note (1)]	[Note (2)]	[Note (2)]	[Note (2)]	[Note (2)]
38	[Note (1)]	[Note (2)]	[Note (2)]	[Note (2)]	[Note (2)]
40	[Note (1)]	[Note (2)]	[Note (2)]	[Note (2)]	[Note (2)]
42	[Note (1)]	[Note (2)]	[Note (2)]	[Note (2)]	[Note (2)]
44	[Note (1)]	[Note (2)]	[Note (2)]	[Note (2)]	[Note (2)]
46	[Note (1)]	[Note (2)]	[Note (2)]	[Note (2)]	[Note (2)]
48	[Note (1)]	[Note (2)]	[Note (2)]	[Note (2)]	[Note (2)]
50	[Note (1)]	[Note (2)]	[Note (2)]	[Note (2)]	[Note (3)]
52	[Note (1)]	[Note (2)]	[Note (2)]	[Note (3)]	
56	[Note (1)]	[Note (2)]	[Note (2)]	[Note (2)]	[Note (3)]
58	[Note (1)]	[Note (2)]	[Note (2)]	[Note (2)]	[Note (3)]
60	[Note (1)]	[Note (2)]	[Note (2)]	[Note (2)]	[Note (3)]

## GENERAL NOTES:

- (a) This table shows the maximum bore of flanges for which the spiral-wound gasket dimensions shown in Table SW-2.1-2 are recommended, considering the tolerances involved, the possibility of eccentric installation, and the possibility that the gasket may extend into the assembled flange bore.
- (b) Refer to para. SW-2.5 for required use of inner rings.

## NOTES:

- (1) Applies only to welding neck flanges with a bore not larger than the inside diameter of a 4.75-mm (0.187-in.) wall pipe. Larger bores must be checked individually.
- (2) Applies only to welding neck flanges with a bore not larger than the inside diameter of a 6.4-mm (0.25-in.) wall pipe, except that NPS 38, Class 300 is not suitable for a bore larger than the inside diameter of a 7.6-mm (0.30-in.) wall pipe. Larger bores must be checked individually.
- (3) There are no Class 900 flanges in NPS 50 and larger.

**Table SW-2.5-4**  
**Maximum Bore of ASME B16.47 Series B Flanges for Use With Spiral-Wound Gaskets**

Flange Size (NPS)	Maximum Bore by Pressure Class				
	150	300	400	600	900
26	[Note (1)]	[Note (1)]	[Note (1)]	[Note (1)]	[Note (1)]
28	[Note (1)]	[Note (1)]	[Note (1)]	[Note (1)]	[Note (1)]
30	[Note (1)]	[Note (1)]	[Note (1)]	[Note (1)]	[Note (1)]
32	[Note (1)]	[Note (1)]	[Note (1)]	[Note (1)]	[Note (1)]
34	[Note (1)]	[Note (1)]	[Note (1)]	[Note (1)]	[Note (1)]
36	[Note (1)]	[Note (1)]	[Note (1)]	[Note (1)]	[Note (1)]
38	[Note (1)]	[Note (1)]	[Note (1)]	[Note (1)]	[Note (1)]
40	[Note (1)]	[Note (1)]	[Note (1)]	[Note (1)]	[Note (1)]
44	[Note (1)]	[Note (1)]	[Note (1)]	[Note (1)]	[Note (1)]
46	[Note (1)]	[Note (1)]	[Note (1)]	[Note (1)]	[Note (1)]
48	[Note (1)]	[Note (1)]	[Note (1)]	[Note (1)]	[Note (1)]
50	[Note (1)]	[Note (1)]	[Note (1)]	[Note (1)]	[Note (2)]
52	[Note (1)]	[Note (1)]	[Note (1)]	[Note (1)]	[Note (2)]
54	[Note (1)]	[Note (1)]	[Note (1)]	[Note (1)]	[Note (2)]
56	[Note (1)]	[Note (1)]	[Note (1)]	[Note (1)]	[Note (2)]
58	[Note (1)]	[Note (1)]	[Note (1)]	[Note (1)]	[Note (2)]
60	[Note (1)]	[Note (1)]	[Note (1)]	[Note (1)]	[Note (2)]

## GENERAL NOTES:

- (a) This table shows the maximum bore of flanges for which the spiral-wound gasket dimensions shown in Table SW-2.1-3 are recommended, considering the tolerances involved, the possibility of eccentric installation, and the possibility that the gasket may extend into the assembled flange bore.
- (b) Refer to para. SW-2.5 for required use of inner rings.

## NOTES:

- (1) Welding neck and integral flanges having maximum inside diameters as described in ASME B16.47.
- (2) There are no Class 900 flanges in NPS 50 and larger.

**Table SW-3-1**  
**Color Coding and Abbreviations for Spiral-Wound Gasket Materials**

(23)

Material	Abbreviation	Color Code	UNS Reference
<b>Metallic Winding Materials</b>			
Carbon steel	CRS	Silver	...
Type 304 SS	304	Yellow	S30400
Type 304L SS	304L	No color	S30403
Type 304 H SS	304 H	No color	S30409
Type 309 SS	309	No color	S30900
Type 310 SS	310	No color	S31000
Type 316 SS	316	No color	S31600
Type 316L SS	316L	Green	S31603
Type 316 Ti SS	316 Ti	No color	S31635
Type 317L SS	317L	Maroon	S31703
Type 321 SS	321	Turquoise	S32100
Type 321H SS	321H	No color	S32109
Type 347 SS	347	Blue	S34700
Type 347H SS	347H	No color	S34709
Type 410 SS	410	No color	S41000
Type 430 SS	430	No color	S43000
Type 904L SS	904L	No color	N08904
Type AL-6XN	AL-6XN	No color	N08367
Type 254 SMO	254 SMO	No color	S31254
Duplex 2205	2205	No color	S32205
Duplex 2507	2507	No color	S32750
17-7 PH	17-7 PH	No color	S17700
Ni-Cu	...	...	...
Monel 400	MON	Orange	N04400
Grade 400	...	...	N04400
Nickel 200	NI	Red	N02200
Titanium, Grade 2	TI 2	Purple	R50400
Titanium, Grade 7	TI 7	Purple	R52400
Carpenter 20Cb3	A-20	Black	N08020
Ni-Mo	...	...	...
Hastelloy B	HAST B	Brown	N10001
Hastelloy B-2	HAST B-2	Brown	N10665
Hastelloy B-3	HAST B-3	Brown	N10675
Ni-Mo-Cr	...	...	...
Hastelloy C	HAST C	Beige	N10276
Alloy C276	HAST C276	Beige	N10276
Hastelloy C-22	HAST C-22	Beige	N06022
HASTELLOY C-2000	HAST C-2000	Beige	N06200
Hastelloy X	HAST X	No color	N06002
Ni-Cr-Fe	...	...	...
Inconel 600	INC 600	Gold	N06600
Grade 600	...	Gold	N06600
Ni-Cr-Fe-Cb	...	...	...
Alloy 625	INC 625	Gold	N06625
Grade 625	...	Gold	N06625
Ni-Cr-Fe-Ti	...	...	...
Inconel X750	INC X750	No color	N07750
Grade X-750	...	...	N07750

**Table SW-3-1**  
**Color Coding and Abbreviations for Spiral-Wound Gasket Materials (Cont'd)**

Material	Abbreviation	Color Code	UNS Reference
<b>Metallic Winding Materials (Cont'd)</b>			
Inconel X-7750 HT	INC X750-HT	No color	N07750
Inconel 718	INC 718	No color	N07718
Ni-Fe-Cr	...	...	...
Alloy 800	IN 800	White	N08800
Grade 800	...	...	N08800
Alloy 800H	INC 800H	White	N08810
Ni-Fe-Cr-Mo-Cu	...	...	...
Incoloy 825	IN 825	White	N08825
Grade 825	...	...	N08825
Copper	Copper	No color	...
Tantalum	TA	No color	...
Zirconium	ZIRC	No color	...
<b>All Other Materials</b>	Manufacturer's standard	No color	
<b>Nonmetallic Filler Materials</b>			
Polytetrafluoroethylene	PTFE	White stripe	...
Vermiculite	...	Light blue stripe	...
Phlogopite (magnesium mica)	...	Light blue stripe	...
Flexible graphite	FG	Gray stripe	...
Ceramic	CER	Light green stripe	...

**Table SW-4.1-1**  
**Example Markings for Spiral-Wound Gaskets**

Description	Marking
NPS 3, Classes 300 and 600 ASME B16.5 gaskets having a Type 304 metal winding and a flexible graphite filler material	[Manufacturer name or trademark] 3-300/600 — FG — ASME B16.20
NPS 36, Class 300 ASME B16.47 Series A gasket having a Type 304 metal winding and a ceramic filler material	[Manufacturer name or trademark] 36-300 — CER ASME B16.47 A — ASME B16.20
NPS 12, Class 1500 ASME B16.5 gasket having an Inconel metal winding, PTFE filler material, and an Inconel inner ring	[Manufacturer name or trademark] 12-1500 INC 600 — PTFE INC 600 I.R. — ASME B16.20

**PART JA  
JACKETED GASKETS**

(23)

**DELETED**

ASMENORMDOC.COM : Click to view the full PDF of ASME B16.20 2023

# PART GM

## GROOVED METAL GASKETS WITH COVERING LAYERS

### GM-1 SIZE AND CLASS

Grooved metal gaskets with covering layers having a centering ring are identified by flange size (NPS), pressure class, and the appropriate flange standard (ASME B16.5 or ASME B16.47).

### GM-2 DIMENSIONS AND TOLERANCES

#### GM-2.1 General

Dimensions and tolerances for grooved metal gaskets with covering layers and centering rings shall be as specified in this Part and in accordance with [Figure GM-2.1-1](#) and [Tables GM-2.1-1](#) through [GM-2.1-3](#).

#### GM-2.2 Construction

Grooved metal gaskets with covering layers shall be constructed as a concentrically grooved metal core (sealing element) with a centering ring. The grooved metal portion of the finished gasket shall be faced with a covering layer on both sealing surfaces that is 0.46 mm to 0.56 mm (0.018 in. to 0.022 in.) thick. The thickness of the metal core of the gasket shall be 2.97 mm to 3.33 mm (0.117 in. to 0.131 in.). The thickness on any single gasket shall be uniform within a maximum tolerance range of 0.13 mm (0.005 in.).

#### GM-2.3 Welding

Welding is permitted only in NPS 14 and larger gaskets. Welding shall be subject to the following:

- (a) Full penetration welds shall be used.
- (b) Where only two welds are used, the minimum weld spacing shall be 152 mm (6 in.). Where more than two welds are required, minimum weld spacing shall be 609 mm (24 in.). Weld spacing shall be measured along the inside circumference of the metal core. When material availability precludes this weld spacing, then additional welding, as agreed by the purchaser and manufacturer, is permitted.

(c) The grooves shall be machined into the core after welding.

(d) In welded areas, the groove, peak profile, and base metal shall be uniform in spacing, thickness, and height with the adjacent metal core.

(e) When specified by the purchaser, weld inspection methods, such as ultrasonic or radiographic, along with acceptance criteria, shall be established.

#### GM-2.4 Centering Ring

A centering ring is required and used to help position the gasket within the flange bolt circle. Unless otherwise specified by the purchaser, the centering ring shall have a nominal thickness of 1.6 mm (0.06 in.) and shall be suitably attached to the grooved metal core using an integral (one-piece or welded) or nonintegral attachment method. The thickness of the centering ring shall not exceed the thickness of the core.

### GM-3 MATERIALS

#### GM-3.1 Covering

Covering material shall be selected from [Table GM-3.1-1](#).

#### GM-3.2 Core

Core material shall be selected from [Table GM-3.1-1](#).

#### GM-3.3 Centering Ring

When carbon steel centering rings are selected, they shall be painted, metal plated, or otherwise coated to inhibit atmospheric corrosion.

### GM-4 MARKING

#### GM-4.1 General

The centering ring shall be permanently marked. The lettering height shall be a minimum of 2.5 mm (0.1 in.), except where space requirements dictate use of a smaller size character. The following information shall be included:

- (a) manufacturer's name or trademark.
- (b) flange size (NPS).
- (c) pressure class.
- (d) metal core abbreviation (see [Table GM-3.1-1](#)), except that the abbreviation may be omitted when Type 304 stainless steel is used.
- (e) covering material abbreviation (see [Table GM-3.1-1](#)).

(f) centering-ring metal abbreviation (see [Table GM-3.1-1](#)).

(g) flange identification. Gaskets used for ASME B16.47 flanges shall be marked B16.47 A or B16.47 B, as applicable. Illustrative marking examples are shown in [Table GM-4.1-1](#). See also [Figure GM-4.1-1](#).

(h) ASME B16.20 designation.

#### **GM-4.2 Pressure Class**

Gaskets suitable for more than one pressure class shall be marked with all applicable classes, as shown in [Table GM-4.1-1](#).

#### **GM-4.3 Color Coding**

Gaskets shall be marked with a color code that identifies the metal core and facing materials. A continuous color around the outer edge of the centering ring shall identify the core metal. The color identifying the facing material for NPS 3 and larger shall have a minimum of four stripes equally spaced on the outer edge of the centering ring. Smaller size gaskets shall have a minimum of two stripes 180 deg apart. The colors shall conform to those listed in [Table GM-3.1-1](#). Special material not listed in [Table GM-3.1-1](#) shall not be color coded. Users shall refer to the guide ring marking for material.

ASMENORMDOC.COM : Click to view the full PDF of ASME B16.20-2023



**Figure GM-2.1-1**  
**Grooved Metal Gasket With Covering Layers**

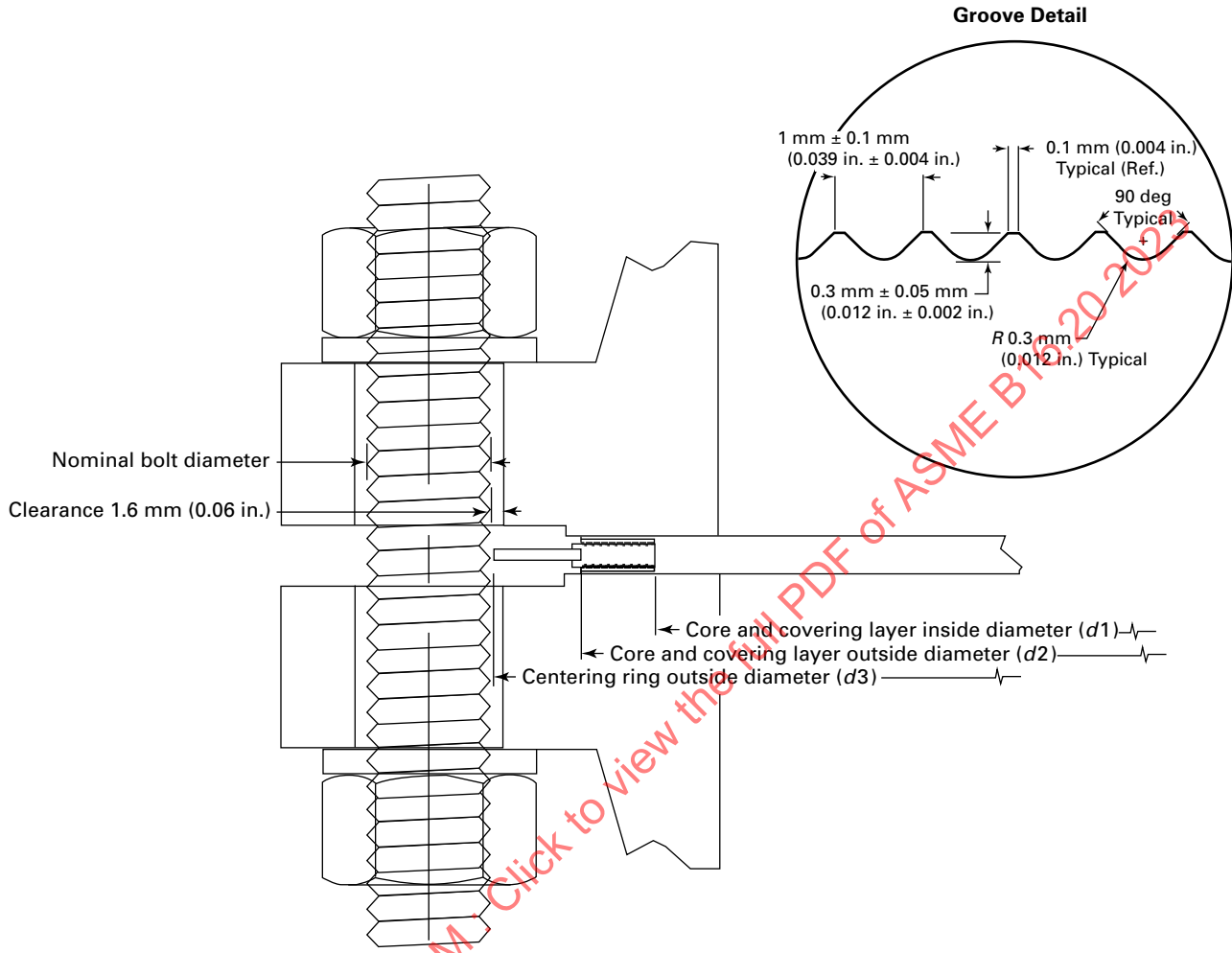

ASME B16.20-2023  
Click to view the full PDF of ASME B16.20-2023  
ASMENORMDOC.COM